



ARMORED POINTER® SWAT VAN

Typically Armored to Level A9/B6+ Against 7.62x39, 5.56x45, 7.62x51, M193, & M80 ball. Can be Armored to Any Level.



ALPINE ARMORING INC.

www.alpineco.com



BASE VEHICLE SPECIFICATIONS

- MAKE:** Mercedes-Benz
- MODEL:** Pointer®
- YEAR:** Brand New
- ENGINE:** 3.0L V6 Turbo Diesel
- POWER:** 154 hp @ 3,400 rpm
- TRANSMISSION:** 4-Speed Automatic
- COLOR:** Client's choice
- INTERIOR:** Vinyl and nylon upholstery
- SEATING:** 2 + 8 crew
- ARMORED WEIGHT:** 10,000 lbs. (4,536 kg.)

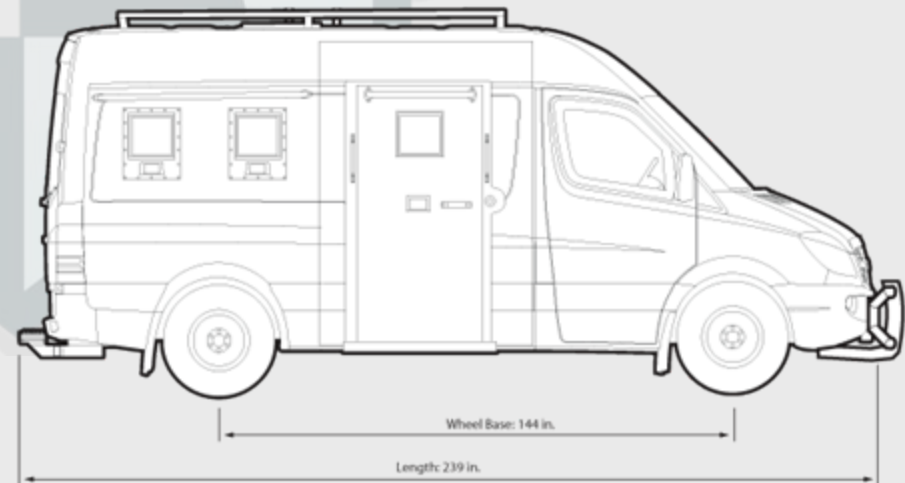
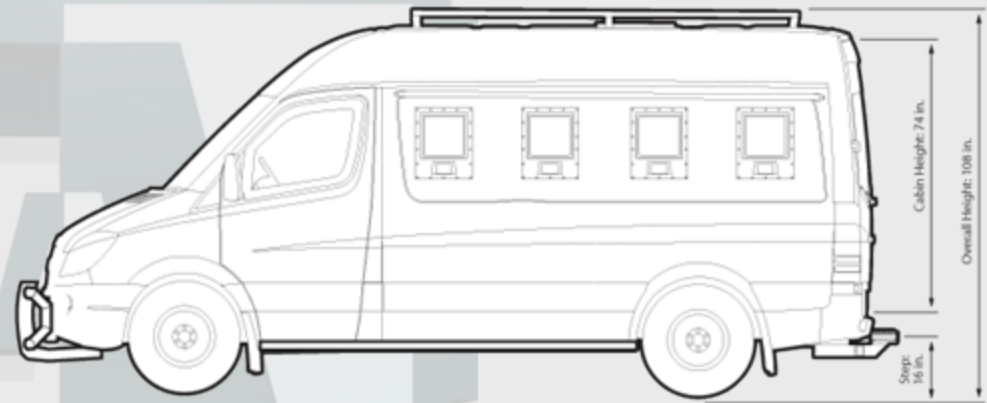
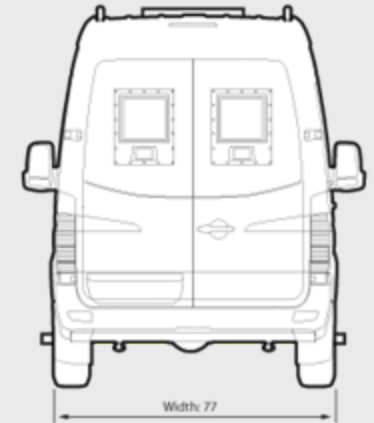
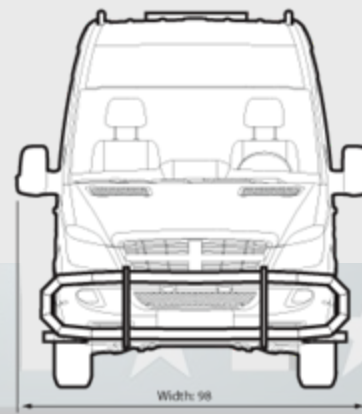



GENERAL ARMORING SPECIFICATIONS

- A. Protection at **Level A9/B6+**, against high power rifles including 7.62x39, 5.56x45, 7.62x51, M193, & M80 ball
- B. Opaque Armor (*see page 4*)
 - 4 mm ballistic steel used for maximum protection
 - Everything from the floor to the battery and fuel tank are protected
- C. Transparent Armor (*see page 5*)
 - 40 mm multi-hit certified ballistic glass/polycarbonate
 - Anti-spall layer
- D. Door Armor (*see page 6*)
 - Overlap for seamless protection
 - Fully reinforced with heavy-duty hinges and locking mechanisms
 - Messenger door for rear cabin
- E. Interior (*see page 7*)
 - Rear seating for team of eight (8)
 - Rear cabin viewing windows and gun ports (x10)
 - Rear cabin messenger door and roof hatch
- F. Audio/Visual Alert Systems (*see page 8*)
 - Strobe lights mounted on front bull bar
- G. Additional Features (*see page 8*)
 - Exterior handle rails, running boards, and low profile rear step
 - Full size front bumper bull bar
 - Detachable roof access ladder
 - Independent A/C system
 - Six (6) run-flat wheel inserts installed





DETAILED ARMORING SPECIFICATIONS

OPAQUE ARMOR

B. Certified 6 & 8 mm ballistic steel is used throughout the entire vehicle

- Additional ballistic steel armoring for the battery, ECM, and fuel tank
- All doors pillars and posts are reinforced with ballistic steel



Certified Ballistic Steel

Protection at **Level A9/B6+**, against high power rifles including: 7.62x39, 5.56x45, 7.62x51, M193, & M80 ball



Internal Body Construction

The entire body of the vehicle's cabin is constructed using ballistic steel, providing uncompromised protection



Ballistic Steel Floor

Protection against mine and DM51 fragmentation grenades



Ballistic Steel Roof

Roof is lined with ballistic steel for maximum overhead protection



Armor Overlap

Provides seamless protection. Used with all doors, windows, and ports



Quality Craftsmanship

Using patented welding and fabrication methods, quality is guaranteed





DETAILED ARMORING SPECIFICATIONS

TRANSPARENT ARMOR

C. All original glass is removed & replaced with NIJ certified multi-layered ballistic glass/polycarbonate



Glass Thickness
40 mm thick glass/polycarbonate



Multi-hit Protection
All windows are capable of sustaining multiple hits while providing protection to passengers



Anti-Spall
Anti-spall layer prevents glass fragments from penetrating into passenger cabin

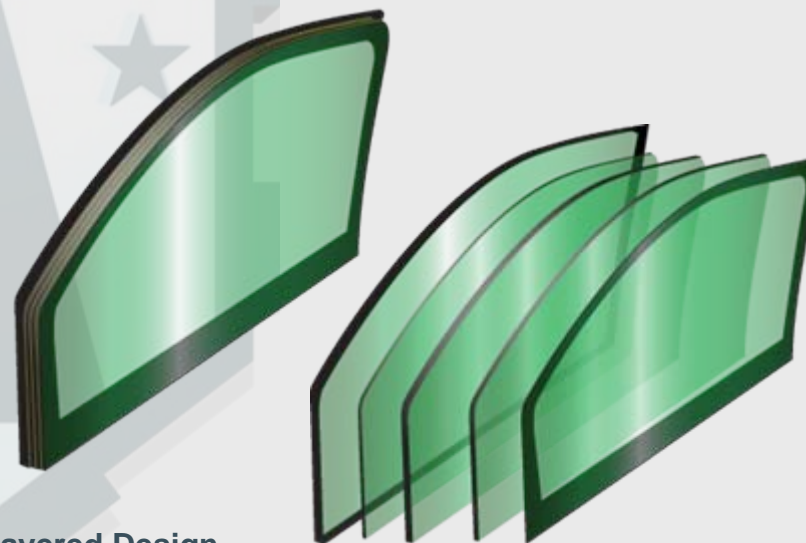

Layered Design
Layered glass and composites protect against multiple hits, providing more time to escape.
Multi-Layered High Optics
Factory tinted Glass/Polycarbonate





DETAILED ARMORING SPECIFICATIONS

DOORS

D. All doors are made with ballistic steel and 40 mm ballistic windows, providing multi-hit protection

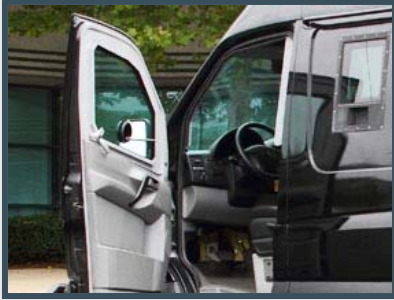

Front Doors

Front doors feature heavy duty locks and gun ports



Rear Doors

Rear features double doors for easy entrance and exit



Door Overlaps

All door overlaps (extra padding used) protect against penetration from every angle



Heavy-Duty Hinges

Ensure smooth and reliable door operation and compensate for the weight of the armoring



Heavy-Duty Door Locks

All doors are equipped with custom heavy-duty locks





DETAILED ARMORING SPECIFICATIONS

INTERIOR/STRUCTURE ARMOR

E. Built around a ballistic steel frame and features viewing windows and gun ports for all occupants

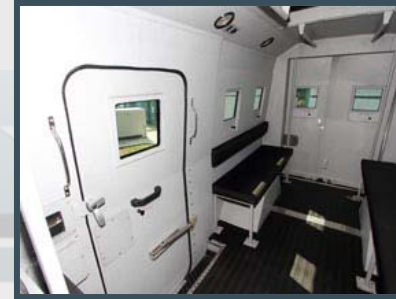

Rear Seating (Passenger Side)

Seats up to 3 people (includes jump seat by messenger door)



Rear Windows/Gun Ports

Rear cabin is outfitted with ten (10) viewing windows and gun ports



Front Windows/Gun Ports

Driver and passenger doors feature individual gun ports integrated into the windows



Roof Hatch

Features integrated roof hatch in the rear cabin. Opening measures 20" x 30"



Messenger Door

Messenger door installed in the rear cabin for easy side exiting and entering. Has built-in viewing window and gun port





DETAILED ARMORING SPECIFICATIONS

AUDIO/VISUAL ALERT SYSTEMS

F. The Pointer® is equipped all necessary public alert systems



Strobes

Red and blue strobes are mounted on the front bumper



GoLight Search Lights

Roof-mounted remote controlled GoLight search lights provide full exterior illumination capabilities (set of two)



GoLight Control

Each GoLight has its own remote control that is mounted on the dashboard



P.A./Multi-Siren System

Features exterior mounted speaker/siren. Interior dash-mounted quick select siren and microphone





DETAILED ARMORING SPECIFICATIONS

ADDITIONAL FEATURES

G. Other features included are pictured below



Rear Cabin A/C System
Rear cabin features a fully independent A/C system



Detachable Ladder
Detachable roof access ladder on the exterior of the van



Exterior
Exterior handle rails, running boards, and low profile rear step



Bull Bar
Full size heavy-duty bull bar mounted to the front bumper



Run-Flat Inserts
Six (6) run-flats installed



Heavy-Duty Jack
Heavy-duty mechanical jack is included. Mounted behind front passenger seat





GENERAL SPECIFICATIONS

OEM FEATURES

- Original dashboard and instruments
- Front climate control with A/C and heater
- Original driver and passenger seats
- Front driver and passenger seatbelts
- All OEM manuals/information included

OPAQUE

- 4 mm ballistic steel (armoring)
- Armor overlap for all doors/windows/ports
- Battery and ECM armor protection
- Ballistic steel fuel tank protection
- Ballistic steel floor (grenade/mine protection)
- Stitch welded plates provide gapless protection

GLASS

- 40 mm glass/polycarbonate construction
- Anti-spall shielding layer
- Multi-hit protection

DOORS

- Overlap protection on doorframes
- Reinforced heavy-duty door hinges
- Heavy-duty door lock mechanisms
- Messenger door for rear cabin

INTERIOR

- Front seating (driver/passenger)
- Driver & passenger door gun ports
- Rear seating for eight (8)
- Jump seat installed by messenger door
- Rear cabin viewing windows (x9)
- Rear cabin gun ports (x8)
- Rear cabin overhead lighting
- Rear cabin roof access hatch (20" x 30")

AUDIO/VISUAL ALERT SYSTEMS

- Strobe lights mounted on front bull bar

ADDITIONAL FEATURES & SECURITY

- Full size heavy-duty front bumper bull bar
- Exterior side running boards
- Exterior rear running board
- Full-length exterior grab handle rails
- Detachable driver side roof access ladder
- Low-profile rear step for quick access
- Six (6) run-flat wheel inserts installed





COMPLETED VEHICLE

EXTERIOR-INTERIOR PHOTOS

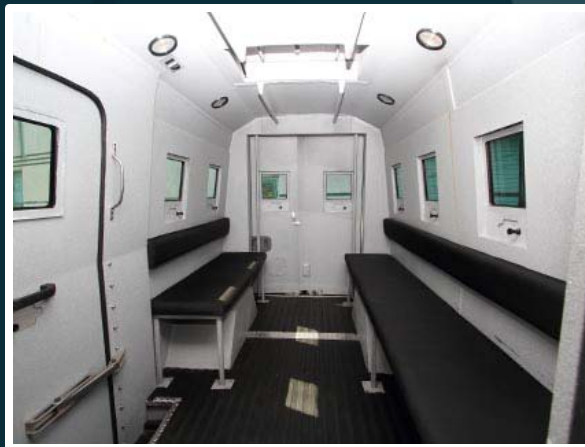
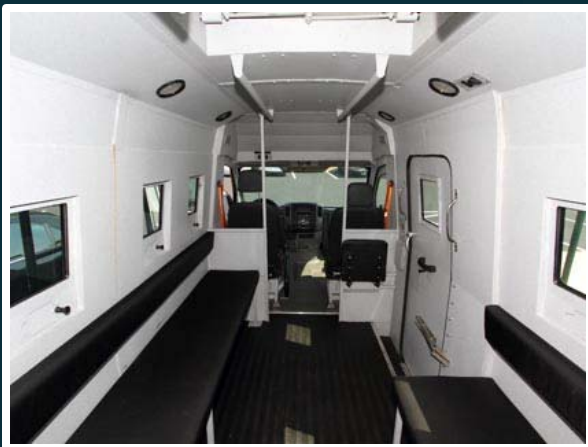

"no one
protects you
better"





ALPINE'S BALLISTIC CHART

ALPINE ARMORING INC.

LEVEL	CALIBER	TYPE	MASS (gram)	MATERIAL	VELOCITY m's (ft's) (a)	SHOTS	STANDARDS			
							UL (b)	NIJ (f)	CEN	DIN
A1	9 x 19 mm	Handgun (Pistol)	8	LCCJ	358 (1,175)	5 (e)	1	I, IIA, II	—	1
A2	.357 Magnum	Handgun (Pistol)	10.2	JSP	430 (1,410)	5 (e)	2	IIA, II	B1, B3	2
A3	.44 Magnum	Handgun (Revolver)	15.6	LWC	440 (1,443)	5 (e)	3	IIIA	B4	3
A4	9 x 19 mm	Sub-machinegun	8	LCCJ	427 (1,400)	5 (e)	6	IIIA	B2	—
A5	7.62 x 25 mm	Handgun (Tokorev)	5.5	LCSJ	488 (1,600)	5 (e)	—	—	—	—
A6	7.62 x 39 mm	AK-47 (HP Rifle)	9.7	SCCJ (d)	732 (2,400)	5 (e)	—	—	—	—
A7	.30 - 06	HP Rifle	11.7	JSP	774 (2,540)	5 (e)	4	—	—	—
A8	5.56 x 45 mm	HP Rifle (M-16)	3.6	LCCJ (d)	991 (3,250)	5 (e)	7	—	B5	4
A9	7.62 x 51 mm	HP Rifle / M193	9.7	LCSJ (d)	838 (2,750)	5 (e)	5, 8	III	B6	5
A10	.30 - 06	HP Rifle	10.8	AP (d)	869 (2,850)	3 (e)	—	IV	B7	—
SG	12 Gauge	Shotgun	28.3	Slug	503 (1,650)	3 (c)	SG	—	SG2	SG2

- UL:** Underwriters Laboratory, 752
- NIJ:** National Institute of Justice, 0108.01
- CEN:** European Standard
- DIN:** German Standards, 52290
- STANAG:** NATO

- LCCJ:** Lead Core Copper Jacket
- JSP:** Jacketed Soft Point
- LWC:** Lead Wad Cutter
- LCSJ:** Lead Core Steel Jacket
- SCCJ:** Steel Core Copper Jacket
- AP:** Armor Piercing
- SG:** Shotgun
- (A)** Minimum Measured Velocity
- (B)** Ambient Temperature Only
- (C)** 11.4 cm Triangular Patter
- (D)** Military Ammunition, All Other Commercial
- (E)** Corners & Center of 11.4 Square Pattern
- (F)** Levels I, II, IIA & IIIA based on 1 of 2 Required Calibers of Ballistic Threat

"no one protects you better"





WARRANTY

MERCEDES-BENZ POINTER® SWAT VAN

The vehicle above is under Alpine's premium warranty covering all its armored parts and labor as well as all added accessories for one full year, effective the date of final delivery to the client.

Alpine Armoring Inc. hereby honors this warranty, in the United States and worldwide, against any and all related manufacturer's defects.

MANAGEMENT AUTHORIZED
ALPINE ARMORING INC.
HERNDON, VIRGINIA, USA

DATE SIGNED

