



ARMORED BULLDOG FX[®] SWAT TRUCK

Typically Armored to Level A9/B6+ Against 7.62x39, 5.56x45, 7.62x51, M193, & M80 ball. Can be Armored to Any Level.



ALPINE ARMORING INC.

www.alpineco.com



BASE VEHICLE SPECIFICATIONS

- MAKE:** Freightliner
- MODEL:** S2 106 Bulldog FX®
- YEAR:** Brand New
- ENGINE:** 6.4L Diesel MB 900
- POWER:** 210 hp @ 2,200 rpm
- TRANSMISSION:** Allison 2100 HS Automatic
- COLOR:** Client's choice
- INTERIOR:** Vinyl and nylon upholstery
- SEATING:** 2 + 10 crew
- ARMORED WEIGHT:** 16,500 lbs. (7,484 kg.)

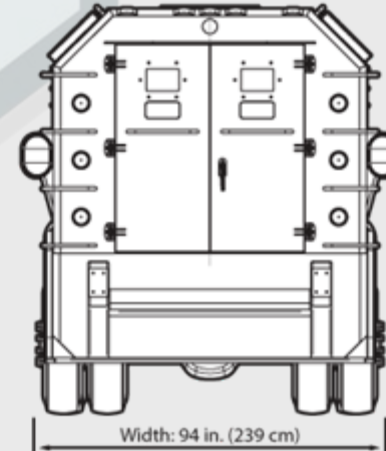
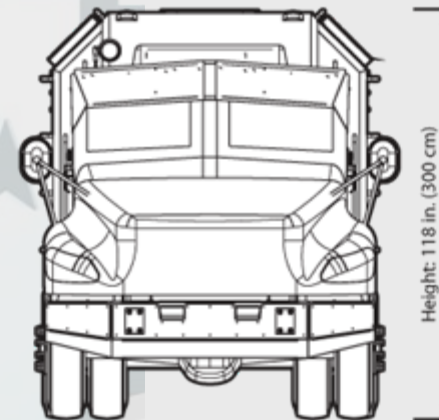
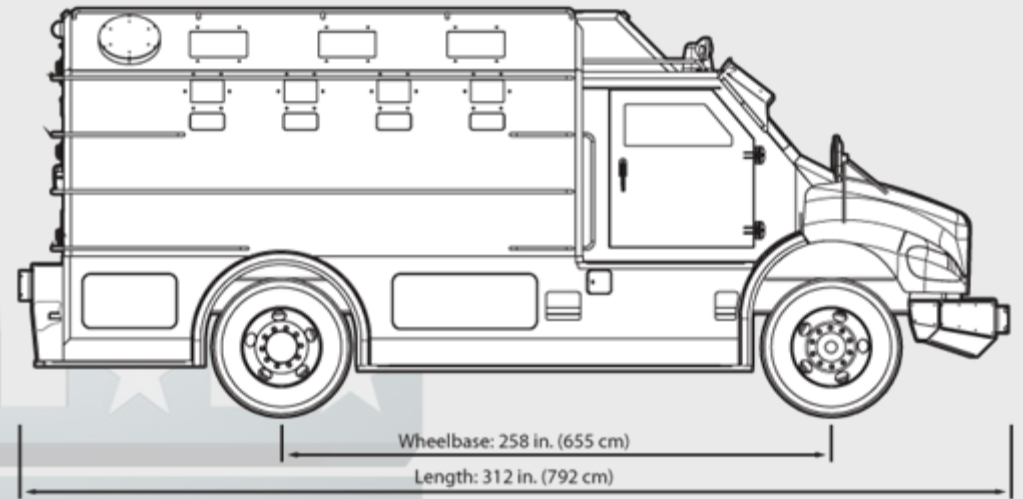



GENERAL ARMORING SPECIFICATIONS

- A. Protection at **Level A9/B6+**, against high power rifles including **7.62x39, 5.56x45, 7.62x51, M193, & M80 ball**
- B. Opaque Armor (*see page 4*)
 - 6 & 8 mm certified ballistic steel used throughout entire vehicle
 - Everything from the floor to the battery and fuel tank are protected
- C. Transparent Armor (*see page 5*)
 - 40 mm multi-hit certified ballistic glass/polycarbonate
 - Anti-spall layer
- D. Door Armor (*see page 6*)
 - Overlap for seamless protection
 - Fully reinforced with heavy-duty hinges and locking mechanisms
- E. Interior/Structure Armor (*see page 7*)
 - Built around a ballistic steel frame
 - Features eight (8) viewing windows/gun ports, roof access, and gear storage
- F. Audio/Visual Alert Systems (*see page 8*)
 - Police bar style roof-mounted strobe lights and remote controlled GoLights (x2)
 - P.A./Multi-siren system
- G. Additional Features (*see page 9*)
 - Exterior grab handle rails, running boards, and low profile rear steps
 - Six (6) run-flat wheel inserts installed
 - Rear cabin independent A/C system and exhaust fans
 - Heavy-duty jack included





DETAILED ARMORING SPECIFICATIONS

OPAQUE ARMOR

B. Certified 6 & 8 mm ballistic steel is used throughout the entire vehicle

- Additional ballistic steel armoring for the battery, ECM, and fuel tank
- All doors pillars and posts are reinforced with ballistic steel



Certified Ballistic Steel

Protection at **Level A9/B6+**, against high power rifles including: 7.62x39, 5.56x45, 7.62x51, M193, & M80 ball



Body Construction

The entire body of the vehicle, inside and out, is constructed using ballistic steel, providing uncompromised protection



Ballistic Steel Floor

Protection against mine and DM51 fragmentation grenades



Armor Overlap

Provides seamless protection. Used with all doors, windows, and ports



Engine Bay

Ballistic steel protects the entire engine bay as well as the radiator



Ballistic Steel Roof

The entire roof is constructed using ballistic steel





DETAILED ARMORING SPECIFICATIONS

TRANSPARENT ARMOR

C. All original glass is removed & replaced with NIJ certified multi-layered ballistic glass/polycarbonate



Glass Thickness
40 mm thick glass/polycarbonate



Multi-hit Protection
All windows are capable of sustaining multiple hits while providing protection to passengers



Anti-Spall
Anti-spall layer prevents glass fragments from penetrating into passenger cabin

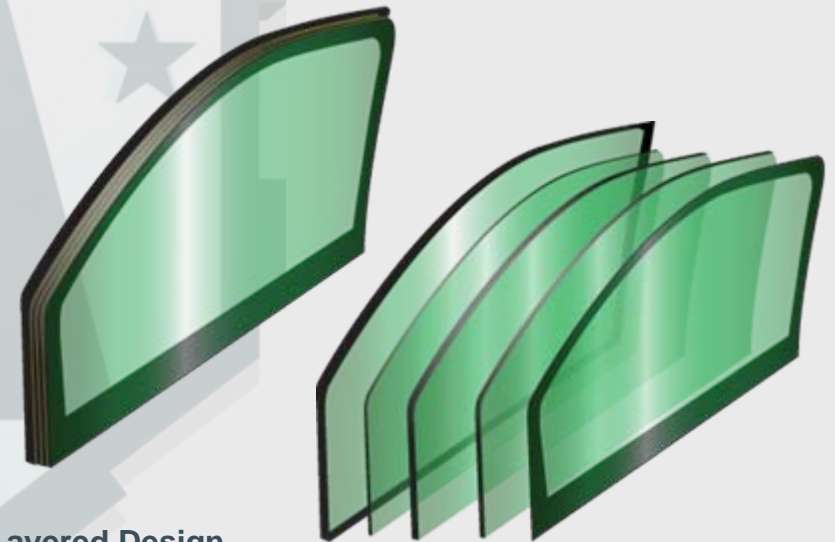

Layered Design
Layered glass and composites protect against multiple hits, providing more time to escape.

Multi-Layered High Optics
Factory tinted Glass/Polycarbonate





DETAILED ARMORING SPECIFICATIONS

DOORS

D. All doors are made with ballistic steel and 40 mm ballistic windows, providing multi-hit protection



Front Doors

Front doors feature heavy duty locks



Rear Doors

Rear features double doors for easy entrance and exit



Door Overlaps

All door overlaps protect against penetration from every angle



Heavy-Duty Hinges

Ensure smooth and reliable door operation and compensate for the weight of the armoring



Heavy-Duty Door Locks

All doors are equipped with custom heavy-duty locks





DETAILED ARMORING SPECIFICATIONS

INTERIOR/STRUCTURE ARMOR

E. Built around a ballistic steel frame and features viewing windows and gun ports for all occupants



Frame Construction

Ballistic steel frame provides extra overlap for all exterior plates and ensures structural rigidity



Rear Seating

Seating for total of eight in rear cabin (four on each side)



Rear Windows/Gun Ports

Rear cabin is outfitted with ten (10) viewing windows and gun ports



Rear Steps

Steps are integrated into the rear bumper for easy entrance into the rear of the vehicle



Roof Hatch

Features integrated roof hatch in the rear cabin



Collapsible Pedestal

Rear cabin features a collapsible pedestal that makes it easier to access the roof hatch



Storage

Rear cabin features built-in gear storage under the passenger seats



Field-Serviceable Wiring

All rear cabin wiring is exposed, making it easy to repair when out in the field





DETAILED ARMORING SPECIFICATIONS

AUDIO/VISUAL ALERT SYSTEMS

F. The Pit-Bull FX is equipped all necessary public alert systems



Roof-Mounted Lighting

All alert lighting is mounted on the roof of the driver's cabin



Red & Blue Lights

Police style bar mounted on the roof



GoLight Search Lights

Roof-mounted remote controlled GoLight search lights provide full exterior illumination capabilities (set of two)



GoLight Control

Each GoLight has its own remote control that is mounted on the dashboard



P.A./Multi-Siren System

Features exterior mounted speaker/siren. Interior dash-mounted quick select siren and microphone





DETAILED ARMORING SPECIFICATIONS

ADDITIONAL FEATURES

G. Other features included are pictured below



Rear Cabin A/C System

Rear cabin features a fully independent A/C system



Air Flow

Two exhaust fans are installed in the rear cabin to ensure optimal air flow



Exterior Grab Handle Rails

Built-in exterior grab handles allow for quick arrival and deployment



Exterior Running Boards

Compliments the exterior grab handles, allowing personnel to ride on the outside



Run-Flat Inserts

Six (6) run-flats installed



Heavy-Duty Jack

Heavy-duty mechanical jack is included. Mounted behind front passenger seat



GENERAL SPECIFICATIONS

OEM FEATURES

- Original dashboard and instruments
- Front climate control with A/C and heater
- Original driver and passenger seats
- All OEM manuals/information included

OPAQUE

- 6 and 8 mm ballistic steel (armoring/construction)
- Armor overlap for all doors/windows/ports
- Battery and ECM armor protection
- Ballistic steel fuel tank protection
- Full engine bay protection including radiator
- Ballistic steel floor (grenade/mine protection)
- Reinforced door pillars and posts

GLASS

- 40 mm glass/polycarbonate construction
- Anti-spall shielding layer
- Multi-hit protection
- Custom tinting available

DOORS

- Overlap protection on doorframes
- Reinforced door pillars
- Reinforced heavy-duty door hinges
- Heavy-duty door lock mechanisms

INTERIOR

- Ballistic steel frame provides extra overlap
- Front seating (driver/passenger)
- Driver & passenger door gun ports
- Front cabin light (red/white x1)
- Rear seating (5 left side/5 right side)
- Rear cabin viewing windows (x8)
- Rear cabin gun ports (x8)
- Rear door viewing windows (x2)
- Rear door gun ports (x2)
- Rear cabin lighting (red/white x6)
- Rear cabin roof access hatch
- Collapsible pedestal on floor (roof access)
- Gear storage under rear cabin seats
- Field-serviceable wiring

AUDIO/VISUAL ALERT SYSTEMS

- Police bar style roof-mounted strobe light
- P.A./Multi-siren system
- Two (2) roof-mounted remote GoLights®

ADDITIONAL FEATURES & SECURITY

- Full-length exterior grab handle rails
- Exterior running boards on the sides/rear
- Low-profile rear steps for quick access
- Mechanically operated heavy-duty jack
- Rear cabin independent A/C system
- Two (2) exhaust fans in the rear cabin
- Six (6) run-flat wheel inserts installed





COMPLETED VEHICLE

EXTERIOR-INTERIOR PHOTOS



"no one protects you better"





ALPINE'S BALLISTIC CHART

ALPINE ARMORING INC.

LEVEL	CALIBER	TYPE	MASS (gram)	MATERIAL	VELOCITY m's (ft's) (a)	SHOTS	UL (b)	NIJ (f)	CEN	DIN
A1	9 x 19 mm	Handgun (Pistol)	8	LCCJ	358 (1,175)	5 (e)	1	I, IIA, II	—	1
A2	.357 Magnum	Handgun (Pistol)	10.2	JSP	430 (1,410)	5 (e)	2	IIA, II	B1, B3	2
A3	.44 Magnum	Handgun (Revolver)	15.6	LWC	440 (1,443)	5 (e)	3	IIIA	B4	3
A4	9 x 19 mm	Sub-machinegun	8	LCCJ	427 (1,400)	5 (e)	6	IIIA	B2	—
A5	7.62 x 25 mm	Handgun (Tokorev)	5.5	LCSJ	488 (1,600)	5 (e)	—	—	—	—
A6	7.62 x 39 mm	AK-47 (HP Rifle)	9.7	SCCJ (d)	732 (2,400)	5 (e)	—	—	—	—
A7	.30 - 06	HP Rifle	11.7	JSP	774 (2,540)	5 (e)	4	—	—	—
A8	5.56 x 45 mm	HP Rifle (M-16)	3.6	LCCJ (d)	991 (3,250)	5 (e)	7	—	B5	4
A9	7.62 x 51 mm	HP Rifle / M193	9.7	LCSJ (d)	838 (2,750)	5 (e)	5, 8	III	B6	5
A10	.30 - 06	HP Rifle	10.8	AP (d)	869 (2,850)	3 (e)	—	IV	B7	—
SG	12 Gauge	Shotgun	28.3	Slug	503 (1,650)	3 (c)	SG	—	SG2	SG2

- UL:** Underwriters Laboratory, 752
- NIJ:** National Institute of Justice, 0108.01
- CEN:** European Standard
- DIN:** German Standards, 52290
- STANAG:** NATO

- LCCJ:** Lead Core Copper Jacket
- JSP:** Jacketed Soft Point
- LWC:** Lead Wad Cutter
- LCSJ:** Lead Core Steel Jacket
- SCCJ:** Steel Core Copper Jacket
- AP:** Armor Piercing
- SG:** Shotgun
- (A)** Minimum Measured Velocity
- (B)** Ambient Temperature Only
- (C)** 11.4 cm Triangular Patter
- (D)** Military Ammunition, All Other Commercial
- (E)** Corners & Center of 11.4 Square Pattern
- (F)** Levels I, II, IIA & IIIA based on 1 of 2 Required Calibers of Ballistic Threat

"no one protects you better"





WARRANTY

★ BULLDOG FX® SWAT TRUCK ★

The vehicle above is under Alpine's premium warranty covering all its armored parts and labor as well as all added accessories for one full year, effective the date of final delivery to the client.

Alpine Armoring Inc. hereby honors this warranty, in the United States and worldwide, against any and all related manufacturer's defects.

MANAGEMENT AUTHORIZED
ALPINE ARMORING INC.
HERNDON, VIRGINIA, USA

DATE SIGNED

