



ARMORED MERCEDES-BENZ G550

Typically Armored to Level A9/B6+ Against 7.62x39, 5.56x45, 7.62x51, M193, & M80 ball. Can be Armored to Any Level.



ALPINE ARMORING INC.

www.alpineco.com



BASE VEHICLE SPECIFICATIONS

- MAKE:** Mercedes-Benz
- MODEL:** G550
- YEAR:** Brand New
- ENGINE:** 5.5L V8 Gasoline
- POWER:** 382 hp @ 6,000 rpm
- TRANSMISSION:** 7-Speed Automatic
- COLOR:** Client's choice
- INTERIOR:** Leather upholstery
- SEATING:** 2 + 3
- ARMORED WEIGHT:** 7,881 lbs. (3,574 kg.)

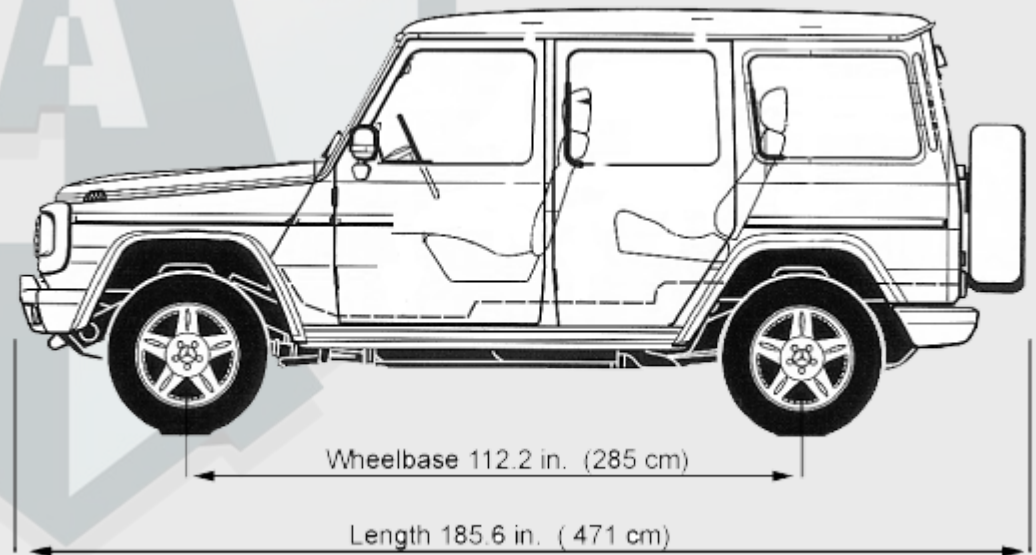
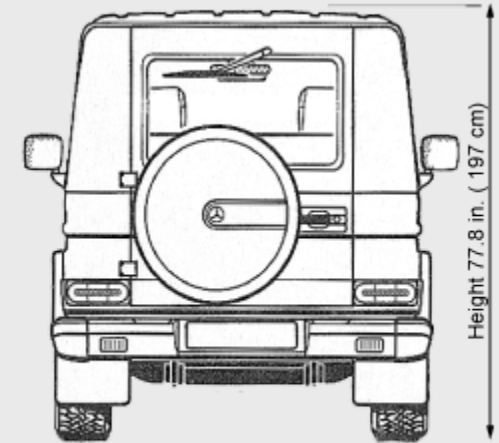



GENERAL ARMORING SPECIFICATIONS

A. Protection at **Level A9/B6+**, against high power rifles including 7.62x39, 5.56x45, 7.62x51, M193, & M80 ball

B. **Opaque Armor** (see page 4-5)

- 4 mm certified ballistic steel used throughout entire vehicle
- Everything from the floor to the battery and fuel tank are protected
- All doors have ballistic steel overlaps

C. **Transparent Armor** (see page 6)

- 40 mm multi-hit certified ballistic glass/polycarbonate
- Anti-spall layer
- Multi-layered design for maximum protection

D. **Additional Features** (see page 7)

- P.A./Multi-siren system
- Built-in intercom system
- Strobes lights mounted behind grill to maintain stock look
- Four (4) run-flat wheel inserts installed
- Tailpipe protection
- Suspension upgrades





DETAILED ARMORING SPECIFICATIONS

OPAQUE ARMOR

B. Protection at **Level A9/B6+**, against high power rifles including: **7.62x39, 5.56x45, 7.62x51, M193, & M80 ball**



Firewall

Ballistic steel firewall provides protection up front



Roof

Roof is lined with ballistic composite at an angle



Floor

Entire floor is lined with ballistic composite or steel

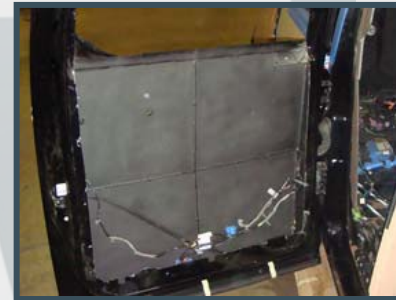

Doors

All doors are lined with ballistic steel



Angle Shot Protection

B pillar reinforcement to protect from angle shots



Heavy Duty Hinges

Custom hinges that will withstand the weight of the armored doors



Fender Armoring

Front side fenders lined with ballistic steel



Wheel Wells

Front and rear wheel wells are lined with ballistic steel





DETAILED ARMORING SPECIFICATIONS

OPAQUE ARMOR Continued



Armor Overlaps

Overlaps are used for all doors and windows



Modified Glass Anchoring

Uses ballistic steel to provide enhanced blast survivability



Rear Door

Ballistic steel lined rear swing door with overlaps and heavy duty hinges



Fuel Tank Protection

Fuel tank is encased in ballistic steel



Engine Computer Protection

ECU is encased in ballistic steel





DETAILED ARMORING SPECIFICATIONS

TRANSPARENT ARMOR

C. All original glass is removed & replaced with NIJ certified multi-layered ballistic glass/polycarbonate



Glass Thickness
40 mm thick glass/polycarbonate



Multi-hit Protection
All windows are capable of sustaining multiple hits while providing protection to passengers



Anti-Spall
Anti-spall layer prevents glass fragments from penetrating into passenger cabin



Power Windows
Lowers approx. 5 inches

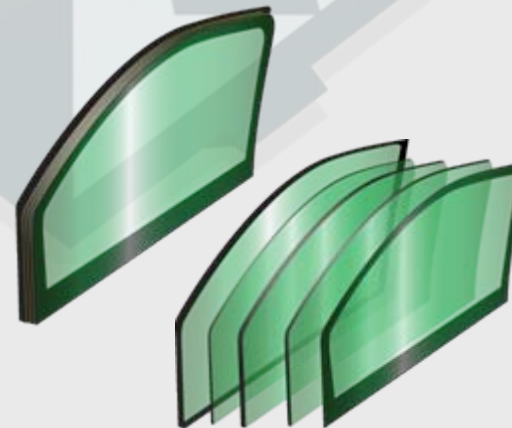

Layered Design
Layered glass and composites protect against multiple hits, providing more time to escape.
Multi-Layered High Optics
Factory tinted Glass/Polycarbonate





DETAILED ARMORING SPECIFICATIONS

ADDITIONAL FEATURES

D. Other features included are pictured below



P.A./Multi-Siren System

Features exterior mounted speaker/siren. Interior dash-mounted quick select siren and microphone



Strobe Lights

Strobes are mounted behind the front grill to maintain a low-profile look



Intercom System

Allows driver to communicate with people outside of the vehicle without opening any windows



Intercom Microphones

Mini microphones are installed outside and in the cabin



Run-Flat Inserts

Four (4) run-flats installed. Rated for 50km/h (30 miles @ 30mph)



Tailpipe Protection

Protects exhaust pipe from being sabotaged



Suspension Upgrades

All springs and shocks are replaced with upgraded models



Reinforced Bumpers

Additional reinforcement mounted behind bumpers. Maintains low-profile look





GENERAL OEM SPECIFICATIONS

- 4-Wheel Electronic Traction System (4-ETS)
- 3 Independent Differential Locks
- Permanent 4-Wheel Drive
- 5 Spoke 18" Alloy Wheels
- Dual Zone Auto Climate Control w/Rear Vents
- Power Telescopic & Tilt Heated Steering Wheel
- COMAND w/DVD Navigation
- Cruise Control
- Front & Rear Heated Seats
- Full Leather Seats
- 10-Way Electric Adj. Front Seats w/Memory
- Driver's Side Multi-Contour Seat
- Foldable Rear Seats 60/40 split
- Rain Sensor for Windshield Wipers
- Harman/Kardon Premium Sound System
- 6 Disc CD Changer
- Trailer Hitch Pre-Wiring
- Running Boards
- Homelink Garage Door Opener
- Telephone Interface
- Rearview Camera
- Rear Park Assist
- Mercedes-Benz Maintenance System
- Electronic Stability Program with Brake Assist
- Power 4 Wheel Disk Brakes w/ABS
- Anti-Theft Alarm System w/Anti-Tow Sensor
- Driver and Passenger Front Airbags
- BabySmart System (Front passenger seat)
- Integrated Blinkers in Side Mirrors
- Seat Belts w/Pre-Tensioners
- Corner Illuminating Front Fog Lamps
- Bi-Xenon Headlamps
- Stainless Steel Spare Tire Cover
- Steering Wheel w/Memory & Menu Function
- Front Headlights Washer System
- Rear Wiper/Washer
- Second Row Center Shoulder Belt
- Window Airbag for 1st & 2nd Row
- Driver Side near Fog Lamp
- Rear Fog Lamp
- TeleAid





COMPLETED VEHICLE

EXTERIOR-INTERIOR PHOTOS



"no one
protects you
better"





ALPINE'S BALLISTIC CHART

ALPINE ARMORING INC.

| LEVEL | CALIBER | TYPE | WEAPONS | | | BULLET | | | STANDARDS | | | |
|-------|--------------|--------------------|-------------|----------|-------------------------|--------|--------|------------|-----------|-----|--|--|
| | | | MASS (gram) | MATERIAL | VELOCITY m's (ft's) (a) | SHOTS | UL (b) | NIJ (f) | CEN | DIN | | |
| A1 | 9 x 19 mm | Handgun (Pistol) | 8 | LCCJ | 358 (1,175) | 5 (e) | 1 | I, IIA, II | — | 1 | | |
| A2 | .357 Magnum | Handgun (Pistol) | 10.2 | JSP | 430 (1,410) | 5 (e) | 2 | IIA, II | B1, B3 | 2 | | |
| A3 | .44 Magnum | Handgun (Revolver) | 15.6 | LWC | 440 (1,443) | 5 (e) | 3 | IIIA | B4 | 3 | | |
| A4 | 9 x 19 mm | Sub-machinegun | 8 | LCCJ | 427 (1,400) | 5 (e) | 6 | IIIA | B2 | — | | |
| A5 | 7.62 x 25 mm | Handgun (Tokorev) | 5.5 | LCSJ | 488 (1,600) | 5 (e) | — | — | — | — | | |
| A6 | 7.62 x 39 mm | AK-47 (HP Rifle) | 9.7 | SCCJ (d) | 732 (2,400) | 5 (e) | — | — | — | — | | |
| A7 | .30 - 06 | HP Rifle | 11.7 | JSP | 774 (2,540) | 5 (e) | 4 | — | — | — | | |
| A8 | 5.56 x 45 mm | HP Rifle (M-16) | 3.6 | LCCJ (d) | 991 (3,250) | 5 (e) | 7 | — | B5 | 4 | | |
| A9 | 7.62 x 51 mm | HP Rifle / M193 | 9.7 | LCSJ (d) | 838 (2,750) | 5 (e) | 5, 8 | III | B6 | 5 | | |
| A10 | .30 - 06 | HP Rifle | 10.8 | AP (d) | 869 (2,850) | 3 (e) | — | IV | B7 | — | | |
| SG | 12 Gauge | Shotgun | 28.3 | Slug | 503 (1,650) | 3 (c) | SG | — | SG2 | SG2 | | |

- UL:** Underwriters Laboratory, 752
- NIJ:** National Institute of Justice, 0108.01
- CEN:** European Standard
- DIN:** German Standards, 52290
- STANAG:** NATO

- LCCJ:** Lead Core Copper Jacket
- JSP:** Jacketed Soft Point
- LWC:** Lead Wad Cutter
- LCSJ:** Lead Core Steel Jacket
- SCCJ:** Steel Core Copper Jacket
- AP:** Armor Piercing
- SG:** Shotgun
- (A)** Minimum Measured Velocity
- (B)** Ambient Temperature Only
- (C)** 11.4 cm Triangular Pattern
- (D)** Military Ammunition, All Other Commercial
- (E)** Corners & Center of 11.4 Square Pattern
- (F)** Levels I, II, IIA & IIIA based on 1 of 2 Required Calibers of Ballistic Threat

"no one protects you better"





★ WARRANTY ★

MERCEDES-BENZ G550

The vehicle above is under Alpine's premium warranty covering all its armored parts and labor as well as all added accessories for one full year, effective the date of final delivery to the client.

Alpine Armoring Inc. hereby honors this warranty, in the United States and worldwide, against any and all related manufacturer's defects.

MANAGEMENT AUTHORIZED
ALPINE ARMORING INC.
HERNDON, VIRGINIA, USA

DATE SIGNED

