



## ARMORED BULLDOG X® SWAT TRUCK

Professionally Armored to Level A10/B7+  
7.62x39, 5.56x45, 7.62x51, and .30-06



This vehicle is available  
for immediate delivery

# ALPINE ARMORING INC.

[www.alpineco.com](http://www.alpineco.com)

## BASE VEHICLE SPECIFICATIONS

<b>MAKE:</b>	Freightliner
<b>MODEL:</b>	Bulldog X2®
<b>VIN:</b>	<b>4UZACPCT17CX80251</b>
<b>YEAR:</b>	2007 (Brand New)
<b>ENGINE:</b>	6.4 L. Diesel MB 900
<b>POWER:</b>	230 hp @ 2,200 rpm
<b>TRANSMISSION:</b>	Allison 2100 HS Automatic
<b>COLOR:</b>	Black
<b>INTERIOR:</b>	Vinyl/Ballistic Nylon
<b>SEATING:</b>	2 + 16
<b>WEIGHT:</b>	26,000 lbs. (Armored)

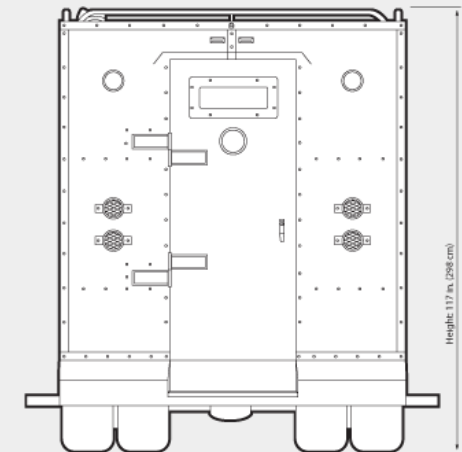
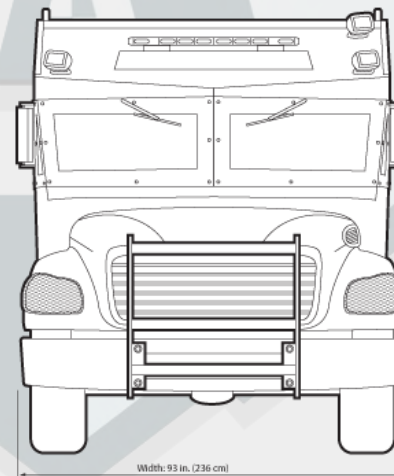
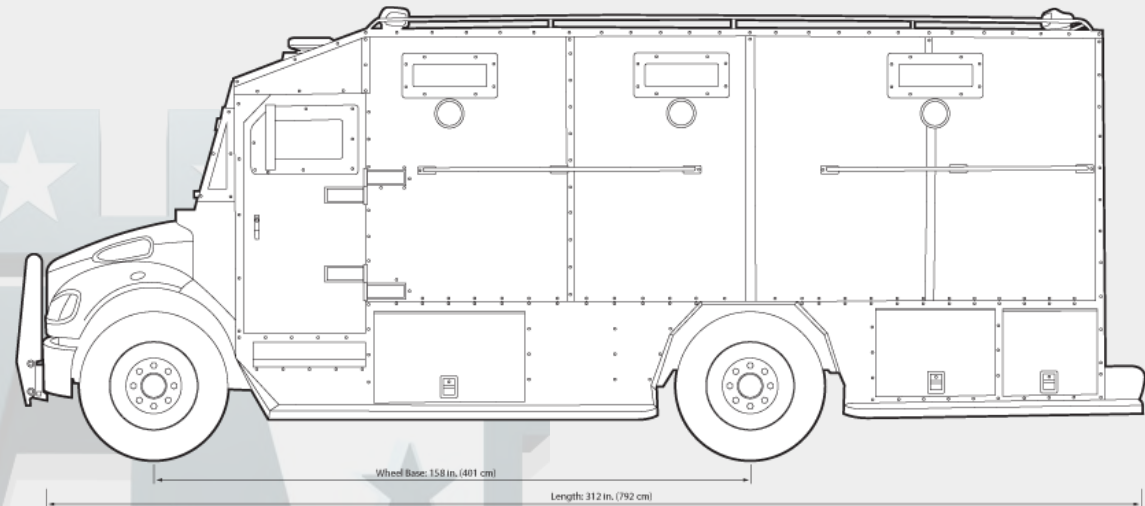

Original Vehicle's [Title](#)

OEM's [Window Sticker](#)

## GENERAL ARMORING SPECIFICATIONS

- A. Protection at **Level A10/B7+**, against high power rifles **including 7.62x39, 5.56x45, 7.62x51, and .30-06**
- B. Opaque Armor (*see page 4*)
- 1/2" thick certified ballistic steel used for maximum protection
  - Everything from the floor to the battery and fuel tank are protected
- C. Transparent Armor (*see page 5*)
- 55 mm multi-hit certified ballistic glass/polycarbonate
  - Anti-spall layer
- D. Door Armor (*see page 6*)
- Overlap for seamless protection
  - Fully reinforced with heavy-duty hinges and locking mechanisms
- E. Interior (*see page 7*)
- Driver and passenger bucket seats
  - Rear seating for sixteen (16)
  - Rear cabin viewing windows (x7)
  - Rear cabin gun ports (x7)
  - Rear cabin overhead lighting (red/white)
  - Rear cabin roof access hatch w/ ladder
  - Gear storage under rear seat cushions
  - Two (2) 25" x 72" rear storage compartments
- F. Audio and Visual Alert Systems (*see page 8*)
- Roof-mounted aerodynamic LED police strobe bar
  - Four (4) remote control GoLight spotlights
  - P.A./Multi-siren system with multi-button interface
- G. Additional Options, Security, and Safety Features (*see page 9*)
- Full size heavy-duty front bumper bull bar
  - Exterior side and rear running boards
  - Full-length exterior handle rails
  - Low-profile rear step for quick access
  - Rear cabin independent A/C and heating
  - Six (6) run-flat wheel inserts installed
  - Tailpipe protection
  - CBRNE options are available

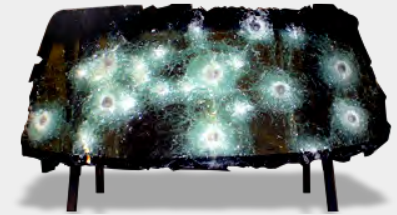

## DETAILED ARMORING SPECIFICATIONS

### OPAQUE ARMOR

- B. 1/2" thick certified ballistic steel is used for maximum protection
- Armor overlaps all doors, windows, and ports
  - Everything from the floor to the battery and fuel tank are protected



#### Certified Ballistic Steel

Protection at **Level A10/B7+**, against high power rifles including: 7.62x39, 5.56x45, 7.62x51, and .30-06



#### Body Construction

The entire body of the vehicle, including the frame, is constructed using ballistic steel, providing uncompromised protection



#### Ballistic Steel Floor

Protection against mine and DM51 fragmentation grenades



#### Ballistic Steel Roof

Roof is lined with ballistic steel for maximum overhead protection



#### Armor Overlap

Provides seamless protection. Used with all doors, windows, and ports

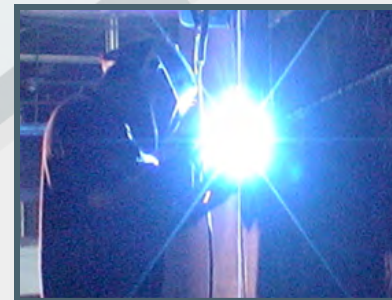

#### Quality Craftsmanship

Using patented welding and fabrication methods, quality is guaranteed

**DETAILED ARMORING SPECIFICATIONS**

**TRANSPARENT ARMOR**

C. Protection at **Level A10/B7**, against high power rifles including **7.62x39, 5.56x45, 7.62x51, and .30-06**



**Window Thickness**  
55 mm thick glass/polycarbonate



**Multi-hit Protection**  
All windows are capable of sustaining multiple hits while providing protection to passengers



**Anti-Spall**  
Anti-spall layer prevents glass fragments from penetrating into passenger cabin



**Layered Design**  
Layered glass and composites protect against multiple hits, providing more time to escape

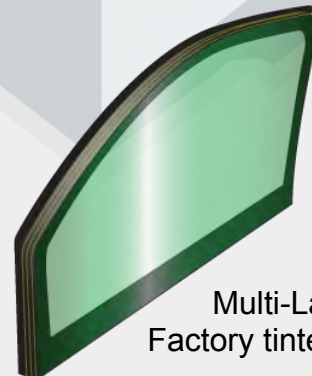
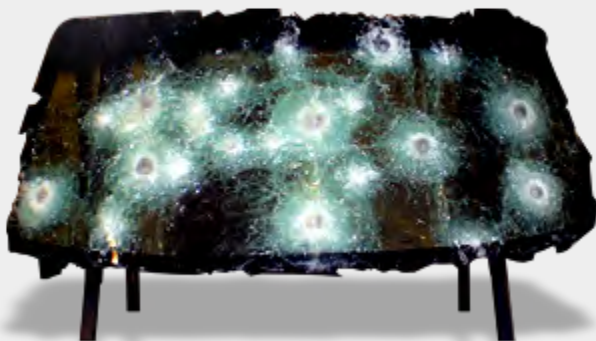

Multi-Layered High Optics  
Factory tinted Glass/Polycarbonate

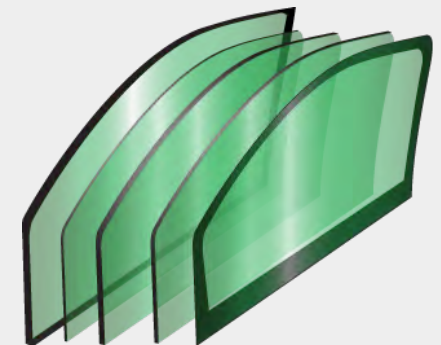

## DETAILED ARMORING SPECIFICATIONS

### DOORS

D. All doors are made with ballistic steel and 55 mm ballistic windows, providing multi-hit protection



#### Front Doors

Front doors feature heavy duty locks and gun ports



#### Rear Door

Rear door features viewing window and gun port

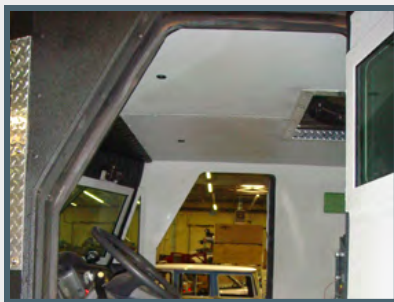

#### Door Overlaps

All door overlaps (extra padding used) protect against penetration from every angle



#### Heavy-Duty Hinges

Ensure smooth and reliable door operation and compensate for the weight of the armoring



#### Heavy-Duty Door Locks

All doors are equipped with custom heavy-duty locks

## DETAILED ARMORING SPECIFICATIONS

### INTERIOR

E. Built around a ballistic steel frame and features viewing windows and gun ports for all occupants



**Rear Seating**  
Seats up to 16 people



**Rear Windows and Gun Ports**  
Total of seven (7) viewing windows with dedicated gun ports under each (includes rear door)



**Roof Hatch**  
Integrated roof hatch in the rear cabin with ladder, provides easy roof access

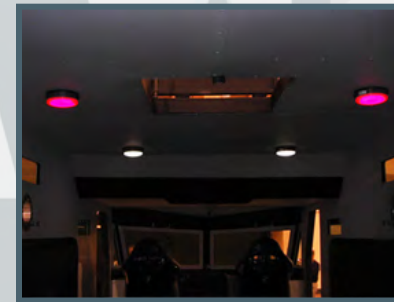

**Rear Cabin Lighting**  
Overhead lighting can be switched between white or red lights



**Rear Cabin Storage Locker**  
Features two (2) 25" x 72" storage lockers



**Rear Seating Storage**  
Rear cabin features gear storage under each seat cushion

**DETAILED ARMORING SPECIFICATIONS****AUDIO AND VISUAL****F. Audio and Visual Alert Systems****Strobe Lights**

Roof-mounted aerodynamic red/blue strobe lights

**GoLights**

Four (4) remote controlled GoLight spotlights are mounted on the front and back of the roof

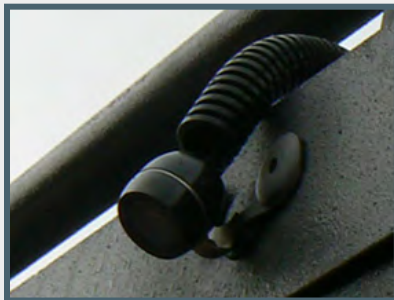
**Rear Mounted Camera**

Mounted directly over the rear door (wide angle lens)

**LCD Monitor**

Can be used for backup and security. Mounted on the front dashboard

**Siren Control Panel**

Multi-button control interface provides quick access to the siren system

**P.A. Microphone**

P.A. system microphone is mounted to the dashboard for quick access to the driver

**DETAILED ARMORING SPECIFICATIONS****ADDITIONAL OPTIONS****G. Additional features and security****Bull Bar**

Full-size heavy-duty bull bar is mounted to the front bumper

**Rear Step**

Built-in low-profile rear exterior step for easy entrance and exit

**Rails and Running Boards**

Integrated exterior handle rails and running boards installed on both sides

**Rear A/C and Heating**

Rear cabin independent A/C and heating system to keep occupants comfortable

**Run-Flat Inserts**

Six (6) run-flats installed

**Tailpipe Protection**

Metal tailpipe mesh is welded to the exhaust pipe for additional protection

## GENERAL OEM SPECIFICATIONS

### OEM FEATURES

- Original dashboard and instruments
- Front climate control with A/C and heater
- All OEM manuals/information included

### OPAQUE

- Half inch thick certified ballistic steel armoring
- Armor overlap for all doors/windows/ports
- Battery and ECM armor protection
- Ballistic steel fuel tank protection
- Ballistic steel floor (grenade/mine protection)
- Stitch welded plates provide gapless protection
- Ballistic steel frame/construction

### GLASS

- 55 mm glass/polycarbonate construction
- Anti-spall shielding layer
- Multi-hit protection

### DOORS

- Overlap protection on doorframes
- Reinforced heavy-duty door hinges
- Heavy-duty door lock mechanisms

### INTERIOR

- Driver and passenger bucket seats
- Rear seating for sixteen (16)
- Rear cabin viewing windows (x7)
- Rear cabin gun ports (x7)
- Rear cabin overhead lighting (red/white)
- Rear cabin roof access hatch
- Roof access ladder
- Gear storage under driver/passenger seats
- Gear storage under rear seat cushions
- Two (2) 25" x 72" rear storage compartments

### AUDIO/VISUAL ALERT SYSTEMS

- Roof-mounted LED police strobe bar
- Four (4) remote control GoLight spotlights
- P.A./Multi-siren system with interface

### ADDITIONAL FEATURES & SECURITY

- Full size heavy-duty front bumper bull bar
- Exterior side running boards
- Exterior rear running board
- Full-length exterior handle rails
- Low-profile rear step for quick access
- Rear cabin independent A/C and heating
- Six (6) run-flat wheel inserts installed
- Rear entrance door camera
- CBRNE options are available



### [OEM Window Sticker](#)

COMPLETED VEHICLE

EXTERIOR-INTERIOR PHOTOS

ALPINE ARMORING INC.

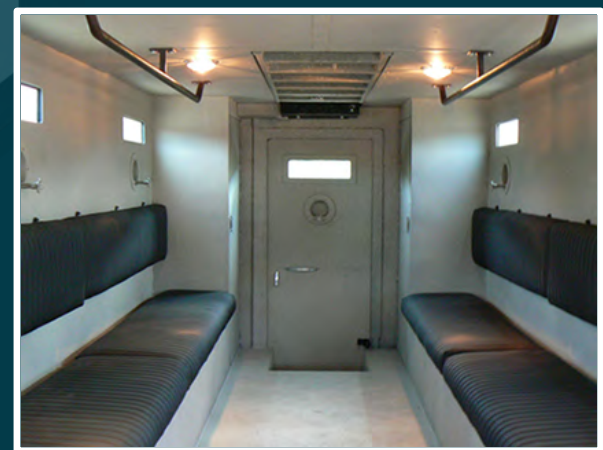
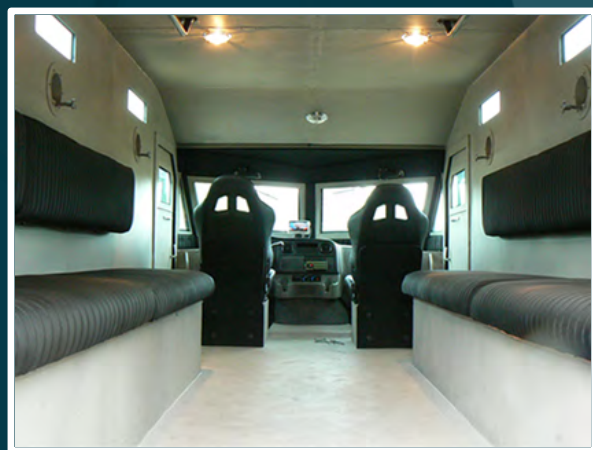

"no one protects you better."



ALPINE'S BALLISTIC CHART

ALPINE ARMORING INC.

LEVEL	CALIBER	TYPE	MASS (gram)	MATERIAL	VELOCITY m/s (ft/s) (a)	SHOTS	STANDARDS			
							UL (b)	NIJ (f)	CEN	DIN
A1	9 x 19 mm	Handgun (Pistol)	8	LCCJ	358 (1,175)	5 (e)	1	I, IIA, II	—	1
A2	.357 Magnum	Handgun (Pistol)	10.2	JSP	430 (1,410)	5 (e)	2	IIA, II	B1, B3	2
A3	.44 Magnum	Handgun (Revolver)	15.6	LWC	440 (1,443)	5 (e)	3	IIIA	B4	3
A4	9 x 19 mm	Sub-machinegun	8	LCCJ	427 (1,400)	5 (e)	6	IIIA	B2	—
A5	7.62 x 25 mm	Handgun (Tokorev)	5.5	LCSJ	488 (1,600)	5 (e)	—	—	—	—
A6	7.62 x 39 mm	AK-47 (HP Rifle)	9.7	SCCJ (d)	732 (2,400)	5 (e)	—	—	—	—
A7	.30 - 06	HP Rifle	11.7	JSP	774 (2,540)	5 (e)	4	—	—	—
A8	5.56 x 45 mm	HP Rifle (M-16)	3.6	LCCJ (d)	991 (3,250)	5 (e)	7	—	B5	4
A9	7.62 x 51 mm	HP Rifle / M193	9.7	LCSJ (d)	838 (2,750)	5 (e)	5, 8	III	B6	5
A10	.30 - 06	HP Rifle	10.8	AP (d)	869 (2,850)	3 (e)	—	IV	B7	—
SG	12 Gauge	Shotgun	28.3	Slug	503 (1,650)	3 (c)	SG	—	SG2	—

- UL:** Underwriters Laboratory, 752
- NIJ:** National Institute of Justice, 0108.01
- CEN:** European Standard
- DIN:** German Standards, 52290
- STANAG:** NATO

- LCCJ:** Lead Core Copper Jacket
- JSP:** Jacketed Soft Point
- LWC:** Lead Wad Cutter
- LCSJ:** Lead Core Steel Jacket
- SCCJ:** Steel Core Copper Jacket
- AP:** Armor Piercing
- SG:** Shotgun
- (A)** Minimum Measured Velocity
- (B)** Ambient Temperature Only
- (C)** 11.4 cm Triangular Patter
- (D)** Military Ammunition, All Other Commercial
- (E)** Corners & Center of 11.4 Square Pattern
- (F)** Levels I, II, IIA & IIIA based on 1 of 2 Required Calibers of Ballistic Threat





# WARRANTY

**FREIGHTLINER BULLDOG X2® SWAT TRUCK**  
VIN: 4UZACPCT17CX80251

The vehicle above is under Alpine's premium warranty covering all its armored parts and labor as well as all added accessories for one full year, effective the date of final delivery to the client.

Alpine Armoring Inc. hereby honors this warranty, in the United States and worldwide, against any and all related manufacturer's defects.

MANAGEMENT AUTHORIZED  
ALPINE ARMORING INC.  
HERNDON, VIRGINIA, USA

\_\_\_\_\_  
DATE SIGNED

Original Vehicle's [Title](#)

OEM's [Window Sticker](#)





# Certificate of Ballistic Standards

FREIGHTLINER BULLDOG X2® SWAT TRUCK  
VIN: 4UZACPCT17CX80251

The vehicle above is hereby certified according to level **A10/B7**. The materials, both opaque and transparent (including ballistic hardened steel, all glass and/or any special composite material), used in armoring this vehicle have been tested and certified by an authorized independent laboratory.

**CONVERSION:** Entire passenger area (Transparent and Opaque), roof, and especially floor, plus firewall and wheel wells. Battery, computer module and fuel tank are also protected.

- Full multi-hit (5 rounds) protection against high power rifles (A10/B7), including **7.62x39, 5.56x45, 7.62x51, and 30-06**
- All original glass is removed and replaced with high quality no spall NIJ tested Multi-layered ballistic polycarbonate/glass
- All opaque materials surrounding the passenger area are replaced with hardened ballistic NIJ certified steel
- All overlap areas are protected separately with multilayered padding on both sides
- Protection for the floor (against mines/fragmentation including two DM51 anti-personnel hand grenade) using ballistic steel
- Protection for the roof (at or above 45° angle) using special ballistic steel
- Fuel tank will be ballistically and independently protected all around
- Separate ballistic protection for the battery, black box/computer module
- Patented design armoring for firewall and all wheel wells

Management  
Alpine Armoring Inc.  
Herndon, Virginia, USA

\_\_\_\_\_  
Date