



ARMORED MERCEDES-BENZ S550

**Professionally Armored to Level A3/B4+
Including .357, 45 magnum, 9mm and Uzi**



**This vehicle is available
for immediate delivery**

ALPINE ARMORING INC.

www.alpineco.com

BASE VEHICLE SPECIFICATIONS

MAKE: Mercedes-Benz

MODEL: S550 4MATIC Sedan

VIN: **WDDNG71X89A243204**

YEAR: 2009 (This Car is Brand New)

ENGINE: 5.5L V-8 Gasoline

POWER: 382 hp @ 6,000 rpm

TRANSMISSION: 7-Speed Driver Adaptive

COLOR: Black (Code 040)

INTERIOR: Black Leather (Code 201)

SEATING: 2 + 3

WEIGHT: 4780 lbs. (Armored)

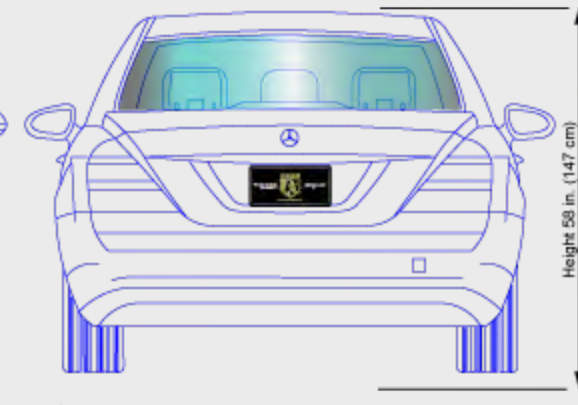
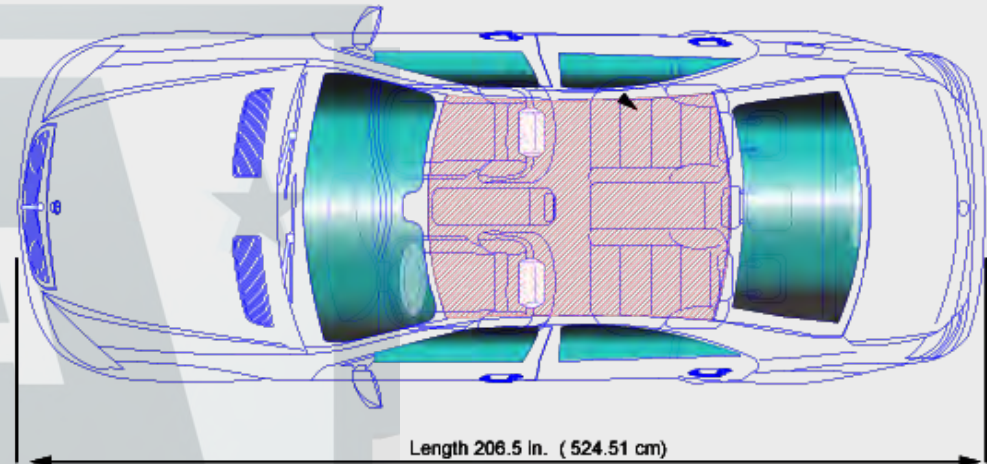
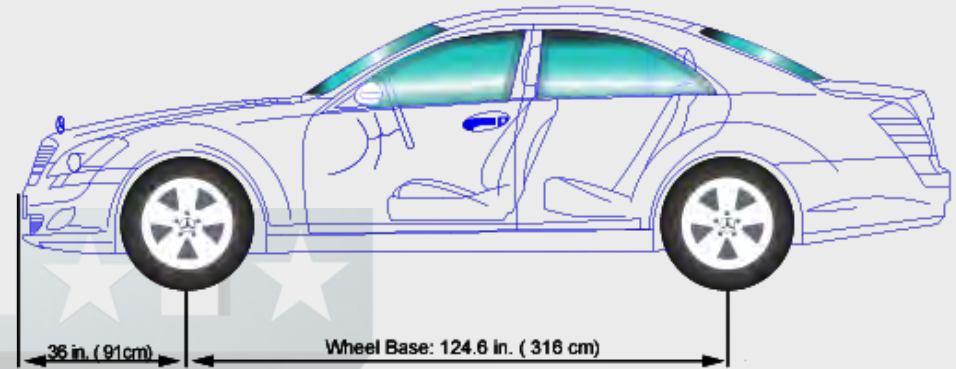

Original Vehicle's [Title](#)

OEM's [Window Sticker](#)

GENERAL ARMORING SPECIFICATIONS

- A. Protection at **Level A3/B4+**, against **.357, 45 magnum, 9mm, and Uzi** (*see page 4*)
- B. All original glass is removed and replaced with NIJ certified multi-layered ballistic glass/polycarbonate (*see page 5*)
- C. Additional areas of armoring are the fuel tank (*see page 6*)
- D. A complete set of four (4) Safety Security Bands for the wheels/tires (*see page 6*)

OPTIONS (included)

- E. Driver and front passenger side power windows (window drops by approx. 4 in.) (*see page 5*)
- F. P.A./Multi-Siren System built-in and accessible to the driver (*see page 7*)

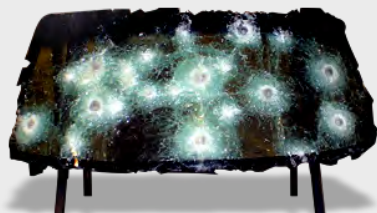

DETAILED ARMORING SPECIFICATIONS

OPAQUE AREAS

A. Protection at **Level A3/B4+**, against high power rifles including **.357, 45 magnum, 9mm, and Uzi**



Composite Materials

Passenger cabin protection using Kevlar and composites



Doors

Protected using ballistic composites



Frame/Structural Protection

Every corner of the interior frame is lined with ballistic composite



Rear Seat Protection

Rear seats are backed with ballistic composite



Roof

Roof is protected using ballistic composite



Floor

Kevlar lined floor for mine and grenade protection

DETAILED ARMORING SPECIFICATIONS

TRANSPARENT AREAS

B. All original glass is removed & replaced with NIJ certified multi-layered ballistic glass/polycarbonate



Using robotic equipment to install the armored glass.



20 mm thickness drops down to 8 cm



Anti-spall layer prevents glass fragments from penetrating into passenger cabin



Layers are designed to protect against multiple hits, providing more time to escape

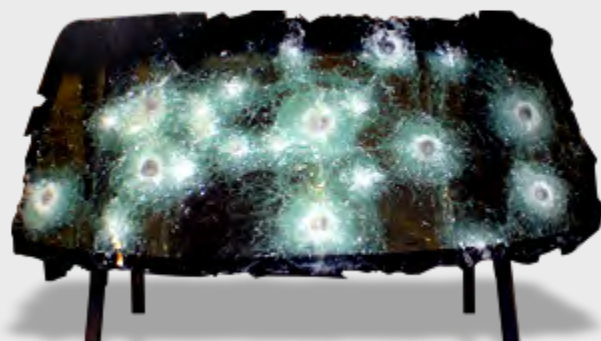

Multi-Layered High Optics
Factory tinted Glass/Polycarbonate

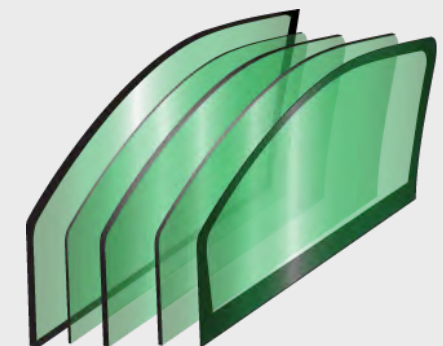

DETAILED ARMORING SPECIFICATIONS

FUEL TANK & RUN-FLATS

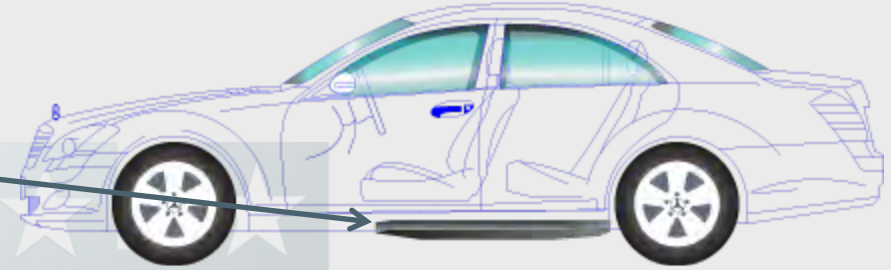

C. Additional areas of armoring are the fuel tank

- Patented protection for sensitive components
- Gas tank is protected externally



D. A complete set of four (4) Safety Security Bands

- Safety Security Bands are the same ones used in emergency vehicles

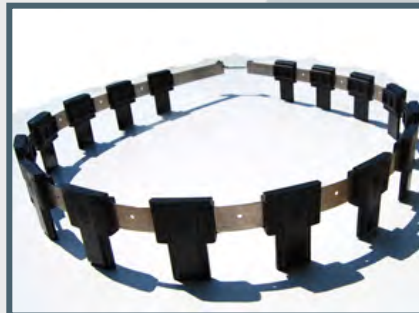



OPTIONS

P.A. SYSTEM



F. Built in Public Address System with Multi-Mode Siren System (accessible by the driver)

- Siren activates via slide switch, power controls, or relay-to-ground connection inputs
- PTT (push to talk) switch on microphone overrides all siren functions
- Optional plug-in microphone with volume control knob.
- Bi-polarity horn/ring control activation.
- Pre-wired unidirectional microphone.
- **Height:** 63mm x **Width:** 152mm x **Depth:** 138mm (interior unit)

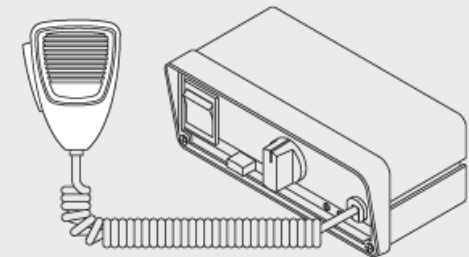
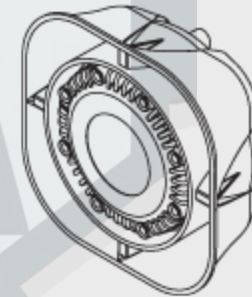

GENERAL OEM SPECIFICATIONS

COMFORT & CONVENIENCE

- AIRMATIC Suspension w/ADS II
- Vented/Cross-Drilled Front Brake Discs
- Vented Rear Brake Discs
- 18" Alloy Wheels
- 255/45 R18 All-Season Tires
- Power Rear Window Sunshade
- Bi-Xenon Active Headlight System
- Headlight/Corner Light Heated Washers
- Electronic Trunk Closer
- COMAND with 20GB Hard-Drive
- GPS Navigation w/Voice Control
- Harman/Kardon Surround Sound System
- In-Dash 6-Disc DVD Changer
- In-Dash Memory Card Reader
- SIRIUS Satellite Radio
- Voice Control for Audio and Phone
- Full Leather Upholstery
- Burl Walnut Wood Trim
- Wood and Leather Steering Wheel
- 14-Way Powered Front Seats
- Active and Ventilated Front Seats
- Front Seats with Lumbar Support
- Dual-Zone Climate Control System
- TeleAid Emergency Calling System
- Adaptive Dual-Stage Front Airbags
- Front and Rear Side Airbags
- Full-Length Head Protection Curtain
- 4-Wheel Anti-Lock Disc Brakes
- Electronic Stability Program (ESP)
- PRE-SAFE (Predictive Protection)
- Occupant Classification System (OCS)
- Antitheft Alarm w/Engine Immobilizer

INCLUDED OPTIONS

- iPod Integration Kit
- Rear View Camera
- PARKTRONIC
- KEYLESS-GO
- Massage Front Seats
- Night View Assist

[OEM Window Sticker](#)



COMPLETED VEHICLE

EXTERIOR-INTERIOR PHOTOS



ALPINE'S BALLISTIC CHART

ALPINE ARMORING INC.

LEVEL	CALIBER	TYPE	MASS (gram)	MATERIAL	VELOCITY m/s (ft/s) (a)	SHOTS	UL (b)	NIJ (f)	CEN	DIN
A1	9 x 19 mm	Handgun (Pistol)	8	LCCJ	358 (1,175)	5 (e)	1	I, IIA, II	—	1
A2	.357 Magnum	Handgun (Pistol)	10.2	JSP	430 (1,410)	5 (e)	2	IIA, II	B1, B3	2
A3	.44 Magnum	Handgun (Revolver)	15.6	LWC	440 (1,443)	5 (e)	3	IIIA	B4	3
A4	9 x 19 mm	Sub-machinegun	8	LCCJ	427 (1,400)	5 (e)	6	IIIA	B2	—
A5	7.62 x 25 mm	Handgun (Tokorev)	5.5	LCSJ	488 (1,600)	5 (e)	—	—	—	—
A6	7.62 x 39 mm	AK-47 (HP Rifle)	9.7	SCCJ (d)	732 (2,400)	5 (e)	—	—	—	—
A7	.30 - 06	HP Rifle	11.7	JSP	774 (2,540)	5 (e)	4	—	—	—
A8	5.56 x 45 mm	HP Rifle (M-16)	3.6	LCCJ (d)	991 (3,250)	5 (e)	7	—	B5	4
A9	7.62 x 51 mm	HP Rifle / M193	9.7	LCSJ (d)	838 (2,750)	5 (e)	5, 8	III	B6	5
A10	.30 - 06	HP Rifle	10.8	AP (d)	869 (2,850)	3 (e)	—	IV	B7	—
SG	12 Gauge	Shotgun	28.3	Slug	503 (1,650)	3 (c)	SG	—	SG2	SG2

- UL:** Underwriters Laboratory, 752
- NIJ:** National Institute of Justice, 0108.01
- CEN:** European Standard
- DIN:** German Standards, 52290
- STANAG:** NATO

- LCCJ:** Lead Core Copper Jacket
- JSP:** Jacketed Soft Point
- LWC:** Lead Wad Cutter
- LCSJ:** Lead Core Steel Jacket
- SCCJ:** Steel Core Copper Jacket
- AP:** Armor Piercing
- SG:** Shotgun
- (A)** Minimum Measured Velocity
- (B)** Ambient Temperature Only
- (C)** 11.4 cm Triangular Patter
- (D)** Military Ammunition, All Other Commercial
- (E)** Corners & Center of 11.4 Square Pattern
- (F)** Levels I, II, IIA & IIIA based on 1 of 2 Required Calibers of Ballistic Threat





WARRANTY

MERCEDES-BENZ S550
VIN: WDDNG71X89A243204

The vehicle above is under Alpine's premium warranty covering all its armored parts and labor as well as all added accessories for one full year, effective the date of final delivery to the client.

Alpine Armoring Inc. hereby honors this warranty, in the United States and worldwide, against any and all related manufacturer's defects.

MANAGEMENT AUTHORIZED
ALPINE ARMORING INC.
HERNDON, VIRGINIA, USA

DATE SIGNED

Original Vehicle's [Title](#)

OEM's [Window Sticker](#)





Certificate of Ballistic Standards

MERCEDES-BENZ S550
VIN: WDDNG71X89A243204

The vehicle above is hereby certified according to level **A3/B4+**. The materials, both opaque and transparent (including ballistic hardened steel, all glass and/or any special composite material), used in armoring this vehicle have been tested and certified by an authorized independent laboratory.

CONVERSION: Entire passenger area (Transparent and Opaque), roof, and especially floor

- Full multi-hit (5 rounds) protection against handguns and small arms (A3/B4+), including **.357, 45 Magnum, 9 mm., and Uzi**
- All original glass is removed and replaced with high quality no spall NIJ tested Multi-layered ballistic polycarbonate/glass
- All opaque materials surrounding the passenger area are replaced with ballistic composite material
- Protection for the floor (against mines/fragmentation including two DM51 anti-personnel hand grenade) using multi-layer blanket (Kevlar)
- Protection for the roof (at or above 45° angle) using special ballistic composite material

Management
Alpine Armoring Inc.
Herndon, Virginia, USA

Date

