



**ARMORED MB S500
S-GUARD EDITION**



**This vehicle is available
for immediate delivery**

ALPINE ARMORING INC.

www.alpineco.com

BASE VEHICLE SPECIFICATIONS

MAKE: Mercedes-Benz
MODEL: S500 S-Guard
VIN: WDBNG75J21A198280
YEAR: 2001
ENGINE: 5.0 L. V8 Gasoline
POWER: 302 hp @ 5,500 rpm
TRANSMISSION: Automatic
COLOR: Silver
INTERIOR: Charcoal Napa Leather
SEATING: 2 + 3
WEIGHT: 5,120 lbs. (Armored)

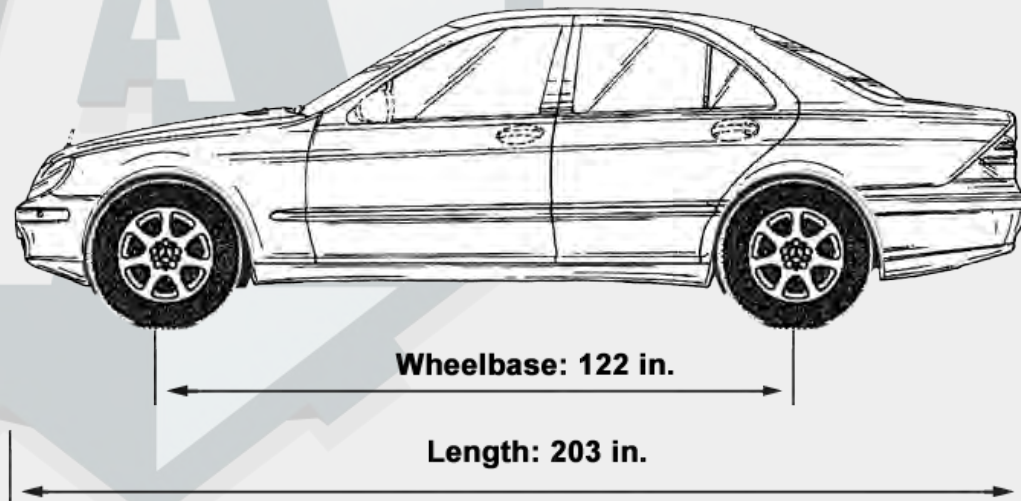
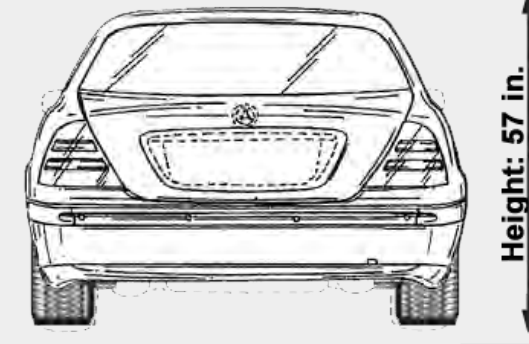
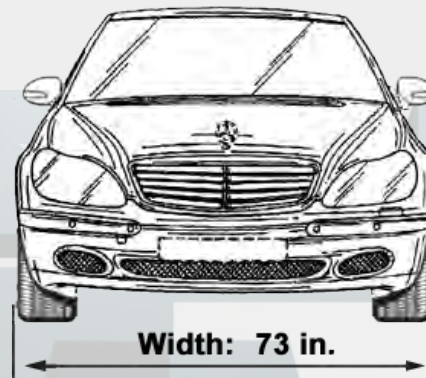

Original Vehicle's [Title](#)

OEM's [Window Sticker](#)

GENERAL ARMORING SPECIFICATIONS

- A. Protection at **Level A3/B4+**, against handguns and small arms including including **.357, .44 magnum, 9 mm, and Uzi**
- B. Certified ballistic steel shell installed between interior and exterior frame/chassis (*see page 4*)
 - Floor has Anti-mine protection including DM51 grenade/fragmentation using ballistic steel
 - Roof (at an angle) using special & lighter ballistic steel for a lower center of gravity
- C. All original glass is removed and replaced with NIJ certified multi-layered ballistic glass/polycarbonate (*see page 5*)
- D. Additional armoring (*see page 6*)
 - Self-sealing fuel tank
- E. Included Options (*see page 6*)
 - Power driver and passenger windows
 - P.A. system
 - A complete set of four (4) safety security bands installed

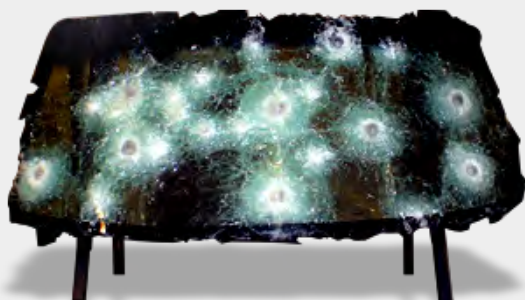

DETAILED ARMORING SPECIFICATIONS

OPAQUE AREAS

B. Certified ballistic steel shell installed between interior and exterior frame/chassis

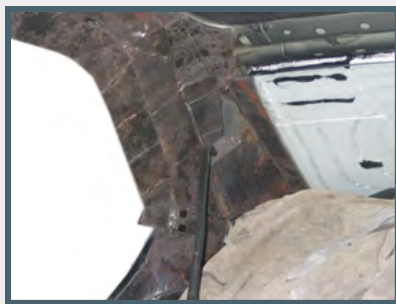

Structure

Ballistic steel is used to provide the best protection possible



Doors

All doors are ballistic steel lined

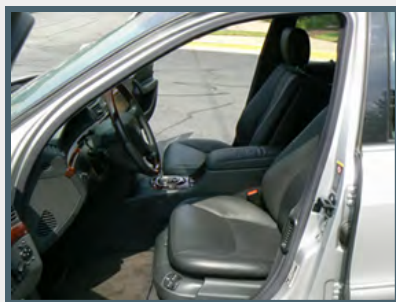

Door Overlaps

All door overlaps (extra padding used) protect against penetration from every angle



Firewall

Ballistic steel firewall provides protection up front



Roof

At a minimum 60 degree angle, using special & lighter ballistic steel for a lower center of gravity



Floor

Protection below with ballistic steel

DETAILED ARMORING SPECIFICATIONS

TRANSPARENT AREAS

C. All original glass is removed & replaced with NIJ certified multi-layered ballistic glass/polycarbonate

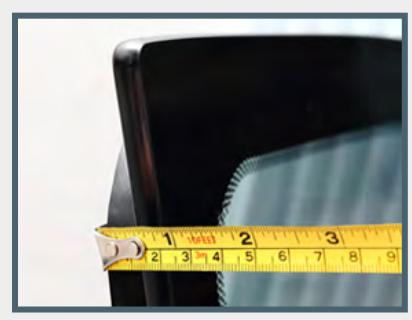

Window Thickness
20 mm thick glass/polycarbonate



Multi-hit Protection
All windows are capable of sustaining multiple hits while providing protection to passengers



Anti-Spall
Anti-spall layer prevents glass fragments from penetrating into passenger cabin



Layered Design
Layered glass and composites protect against multiple hits, providing more time to escape

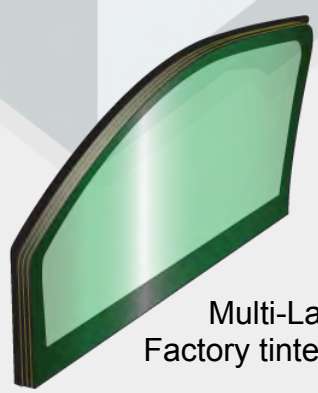
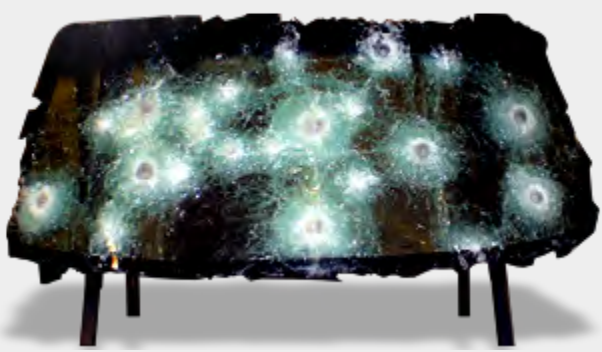

Multi-Layered High Optics
Factory tinted Glass/Polycarbonate

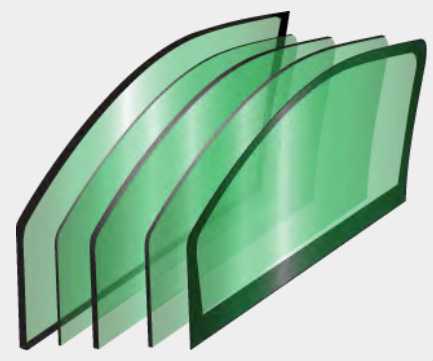

ALPINE ARMORING INC.

"no one protects you better."



DETAILED ARMORING SPECIFICATIONS

ADDITIONAL FEATURES

D. Additional armoring includes self-sealing fuel tank



E. Included options



Power Windows

Driver and passenger windows are powered (open approx. 4 in.)



P.A. System

Gives driver and/or front passenger ability to communicate with others outside of the vehicle



Tire Protection

Complete set of four (4) high grade safety security bands installed

ALPINE ARMORING INC.

"no one protects you better."



GENERAL OEM SPECIFICATIONS

- AIRMATIC Suspension w/Adaptive Damping (ADS)
- Dual-Zone climate control w/charcoal filter
- Napa Leather Upholstery * Burl Walnut Trim
- 10-Speaker Bose Premium System w/Audio Pilot tech
- AM/FM/Weatherband/Cassette Radio
- CD Changer/Phone and Voice Control Pre-wiring
- COMAND Navigation / Audio System
- 14-way Adj. Front Seats w/Lumbar Support
- Integrated Garage Door Opener * Cruise Control
- Intermittent wipers w/rain sensor
- Power Windows w/ Express up & down
- Electric Adj. Tilt/Telescoping Steering Column
- Two way Intercom system
- Active Ventilated Seats/Rear
- Climate Control / Rear Compartment
- Burl walnut Trim
- Infrared reflective glass
- Head Protection Curtains
- 4-wheel ABS disc Brakes w/ Brake Assist System
- Electronic stability Program (ESP)
- Xenon Headlamps w/ Washers
- Automatic Door and trunk closing assist
- Power tilt with heated front seats
- Multi-function steering wheel w/tilt away
- Auto-Dimming Rear / Driver side mirrors with side park
- Self-Sealing Fuel Tank
- PARKTRONIC System
- Electronic Rear Seat Back
- Roller Blinds for Rear Side Windows



COMPLETED VEHICLE
EXTERIOR-INTERIOR PHOTOS

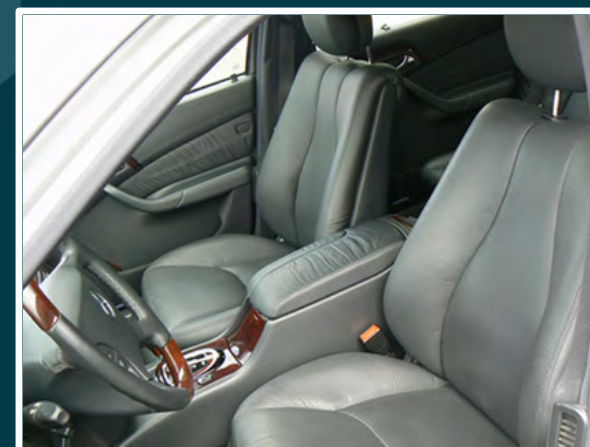
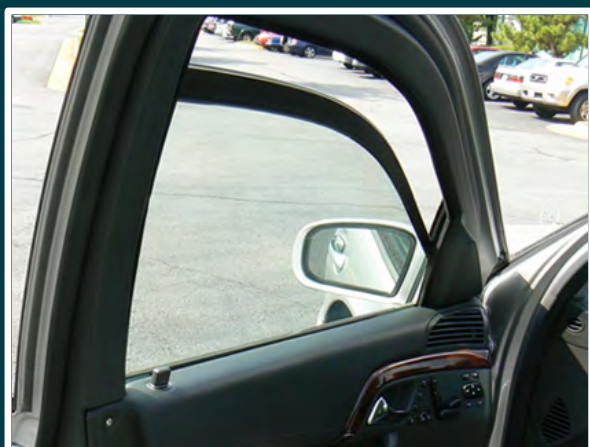

ALPINE ARMORING INC.

"no one
protects you
better."



ALPINE'S BALLISTIC CHART

ALPINE ARMORING INC.

LEVEL	CALIBER	TYPE	MASS (gram)	MATERIAL	VELOCITY m/s (ft/s) (A)	SHOTS	UL (B)	NIJ (F)	CEN	DIN
A1	9 x 19 mm	Handgun (Pistol)	8	LCCJ	358 (1,175)	5 (e)	1	I, IIA, II	—	1
A2	.357 Magnum	Handgun (Pistol)	10.2	JSP	430 (1,410)	5 (e)	2	IIA, II	B1, B3	2
A3	.44 Magnum	Handgun (Revolver)	15.6	LWC	440 (1,443)	5 (e)	3	IIIA	B4	3
A4	9 x 19 mm	Sub-machinegun	8	LCCJ	427 (1,400)	5 (e)	6	IIIA	B2	—
A5	7.62 x 25 mm	Handgun (Tokorev)	5.5	LCSJ	488 (1,600)	5 (e)	—	—	—	—
A6	7.62 x 39 mm	AK-47 (HP Rifle)	9.7	SCCJ (d)	732 (2,400)	5 (e)	—	—	—	—
A7	.30 - 06	HP Rifle	11.7	JSP	774 (2,540)	5 (e)	4	—	—	—
A8	5.56 x 45 mm	HP Rifle (M-16)	3.6	LCCJ (d)	991 (3,250)	5 (e)	7	—	B5	4
A9	7.62 x 51 mm	HP Rifle / M193	9.7	LCSJ (d)	838 (2,750)	5 (e)	5, 8	III	B6	5
A10	.30 - 06	HP Rifle	10.8	AP (d)	869 (2,850)	3 (e)	—	IV	B7	—
SG	12 Gauge	Shotgun	28.3	Slug	503 (1,650)	3 (c)	SG	—	SG2	SG2

- UL:** Underwriters Laboratory, 752
- NIJ:** National Institute of Justice, 0108.01
- CEN:** European Standard
- DIN:** German Standards, 52290
- STANAG:** NATO

- LCCJ:** Lead Core Copper Jacket
- JSP:** Jacketed Soft Point
- LWC:** Lead Wad Cutter
- LCSJ:** Lead Core Steel Jacket
- SCCJ:** Steel Core Copper Jacket
- AP:** Armor Piercing
- SG:** Shotgun
- (A)** Minimum Measured Velocity
- (B)** Ambient Temperature Only
- (C)** 11.4 cm Triangular Patter
- (D)** Military Ammunition, All Other Commercial
- (E)** Corners & Center of 11.4 Square Pattern
- (F)** Levels I, II, IIA & IIIA based on 1 of 2 Required Calibers of Ballistic Threat

"no one protects you better."





WARRANTY

MERCEDES-BENZ S500 S-GUARD

VIN: WDBNG75J21A198280

The vehicle above is under Alpine's premium warranty covering all its armored parts and labor as well as all added accessories for one full year, effective the date of final delivery to the client.

Alpine Armoring Inc. hereby honors this warranty, in the United States and worldwide, against any and all related manufacturer's defects.

MANAGEMENT AUTHORIZED
ALPINE ARMORING INC.
HERNDON, VIRGINIA, USA

DATE SIGNED

Original Vehicle's [Title](#)

OEM's [Window Sticker](#)





Certificate of Ballistic Standards

MERCEDES-BENZ S500 S-GUARD

VIN: WDBNG75J21A198280

The vehicle above is hereby certified according to level **A3/B4+**. The materials, both opaque and transparent (including ballistic hardened steel, all glass and/or any special composite material), used in armoring this vehicle have been tested and certified by an authorized independent laboratory.

CONVERSION: Entire passenger area (Transparent and Opaque), roof, and especially floor, plus firewall and fuel tank are also protected.

- Full multi-hit (5 rounds) protection against high power rifles (A3/B4+), including **.357, .44 magnum, 9 mm, and UZI**
- All original glass is removed and replaced with high quality no spall NIJ tested Multi-layered ballistic polycarbonate/glass
- All opaque materials surrounding the passenger area are replaced with hardened ballistic NIJ certified steel
- All overlap areas are protected separately with multilayered padding on both sides
- Protection for the floor (against mines/fragmentation including two DM51 anti-personnel hand grenade) using ballistic steel
- Protection for the roof (at an angle) using special ballistic steel
- Fuel tank will be ballistically and independently protected all around
- Patented design armoring for firewall

Management
Alpine Armoring Inc.
Herndon, Virginia, USA

Date

