

# THE **SPRINTER**

CARGO VAN

CREW VAN

PASSENGER VAN

CAB CHASSIS/CUTAWAY

WORKER



# SPRINT AHEAD OF THE REST.

The Freightliner Sprinter — the commercial van that launched many imitators — will help you sprint ahead of your competition.

The most advanced commercial van on the road today just took another giant leap forward. In addition to a 2-stage turbo diesel engine,<sup>1</sup> Best-in-Class payload, cargo volume, and interior standing height,<sup>2</sup> the Freightliner Sprinter incorporates advanced safety innovations as well as legendary reliability. The optional 4x4 drive train can help you defeat challenging road and weather conditions as well.

The Sprinter also features Crosswind Assist,<sup>3</sup> the only crosswind-mitigation system in the commercial van segment. This highly advanced standard feature gently engages individual brakes at highway speeds to quickly help stabilize your Sprinter Van and help assure safety and control in strong, gusting crosswinds.

With a class-leading maximum of 563.6 cu. ft.<sup>2</sup> of cargo space, the advantages don't end there. Extended service intervals of up to 20,000 miles<sup>4</sup> help you reduce maintenance costs and vehicle downtime.

While our latest Sprinter Vans continue to raise the bar for innovation and technology, they still hold true to our core values: to create vans that deliver an extraordinary level of performance, durability, and safety to every owner.

Experience the Freightliner Sprinter, the commercial vehicle that helps accelerate your business, raise productivity, and lower the total cost of ownership.

*“The best full-size van for cargo and passenger purposes.”*

— Edmunds







STANDARD HIGHLIGHTS: HIGHER WADING DEPTH | LOW-RANGE GEAR | V6 TURBO DIESEL ENGINE<sup>1</sup> | LOAD-ADAPTIVE ESP<sup>5</sup>

# WEATHER. OR NOT.

Don't let bad weather ruin your good reputation. We're the only manufacturer that will help you get to the job with an on-demand 4-wheel drive commercial van. The Sprinter 4x4 features higher wading depth, a low-range gear, and a standard V6 turbo diesel engine<sup>1</sup> that delivers powerful torque when you need it most.

Plus, it's the only 4x4 that combines Load-Adaptive Electronic Stability Program (ESP<sup>®5</sup>) with Electronic Traction System (4-ETS<sup>®</sup>) to help maintain stability and control by adjusting to road conditions. The Sprinter 4x4 is designed to help keep you safe and on time in challenging road and weather conditions. For other vans, this may seem like going above and beyond. For us, it just means going to work.



The low-range gear accommodates a wide variety of challenging road and weather conditions.

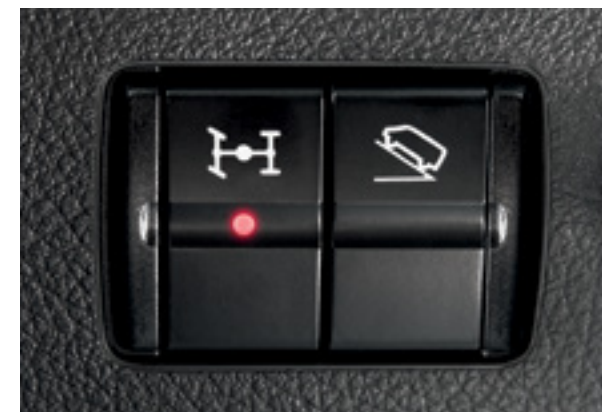

The Sprinter 4x4 option is available in select Cargo, Crew, or Passenger Van configurations.



*"The addition of four-wheel drive means [Sprinter] now offers capability in this segment that newcomers like the Ford Transit and Ram ProMaster do not ...[and] enhances the appeal."<sup>6</sup>*  
—autoblog.com



STANDARD 2.0L 4-CYLINDER TURBO DIESEL ENGINE<sup>1</sup> WITH 7-SPEED TRANSMISSION

"Expect the Sprinter (standard 4-cylinder engine) to achieve significantly better mileage than competitors with gasoline engines." — Edmunds

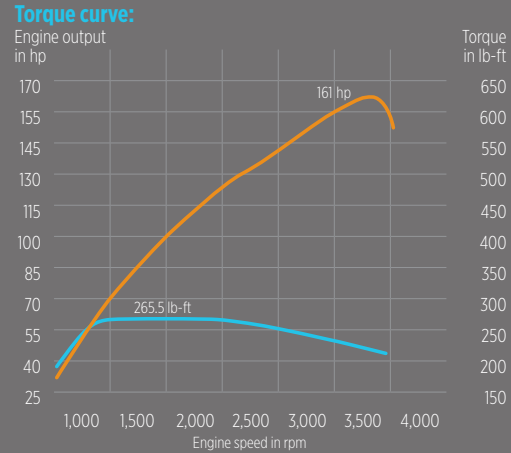

- Diesel engine<sup>1</sup>
- 4-cylinder inline<sup>1</sup>
- Displacement: 2,143 cc
- 161 hp @ 3,800 rpm
- Rated torque: 265.5 lb-ft @ 1,400–2,400 rpm
- Electronically controlled Direct Injection with Commonrail
- 2-stage turbocharging
- Rear-wheel drive
- 7-speed automatic transmission
- Fuel type: Ultra-low-sulfur diesel<sup>1</sup>
- Tank capacity: 24.5 gallons
- Battery: 12V/95 Ah, alternator 14V/200A



OPTIONAL 3.0L V6 TURBO DIESEL ENGINE<sup>1</sup> WITH 5-SPEED TRANSMISSION



"...the tried-and-true 3.0-liter V6 turbo diesel...strong pulling power, good fuel economy and proven longevity." — Kelley Blue Book

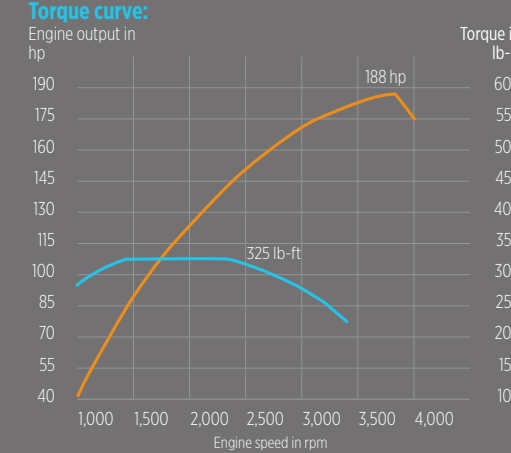

- Diesel engine<sup>1</sup>
- 6-cylinder
- 4 valves per cylinder
- Displacement: 2,987 cc
- 188 hp @ 3,800 rpm
- Rated torque: 325 lb-ft @ 1,400–2,400 rpm
- Electronically controlled Direct Injection with Commonrail
- Turbocharger and intercooler function
- Rear-wheel drive
- 5-speed automatic transmission
- Fuel type: Ultra-low-sulfur diesel<sup>1</sup>
- Tank capacity: 24.5 gallons
- Battery: 12V/100Ah, alternator 14V/220A

STANDARD: 4-CYLINDER ENGINE<sup>1</sup> WITH 7-SPEED TRANSMISSION | LONGER SERVICE INTERVALS OF UP TO 20,000 MILES<sup>2</sup>

OPTIONAL: V6 ENGINE<sup>1</sup> WITH 5-SPEED TRANSMISSION

# ACCELERATE PERFORMANCE.

The engine that drives your business is powered by some of the most advanced technology found in any commercial van. Accelerate performance with a standard 4-cylinder turbo diesel engine<sup>1</sup> that saves you up to 18%<sup>7</sup> on fuel costs versus the 6-cylinder and can lower your total cost of ownership significantly over its working life. For heavy-duty Sprinter applications, an available V6 turbo diesel engine<sup>1</sup> with a 5-speed transmission is the ideal choice. Plus, the optional 4x4 drivetrain with on-demand 4-wheel drive will keep you going even when the weather and road conditions turn bad.

You need torque that's available when the light turns green, when merging onto a highway, and especially under load. The Sprinter's standard engine delivers powerful torque — with virtually zero turbo lag — for performance and acceleration you can feel.



STANDARD HIGHLIGHTS: CROSSWIND ASSIST<sup>3</sup> | LOAD-ADAPTIVE ESP<sup>5</sup> | DRIVER AND PASSENGER AIRBAGS<sup>8</sup> | 3-POINT SEAT BELTS FOR ALL SEATS | RESCUE ASSIST<sup>SM</sup> |

OPTIONAL HIGHLIGHTS: BLIND SPOT ASSIST<sup>9</sup> | LANE KEEPING ASSIST<sup>10</sup> | COLLISION PREVENTION ASSIST<sup>11</sup> | HIGHBEAM ASSIST | REARVIEW CAMERA<sup>12</sup>

## LEADING YOU TO SAFETY.

Your Freightliner Sprinter features dozens of landmark safety innovations that help protect your cargo, your passengers, and your business.

Continuing our heritage as the industry's safety leaders, Freightliner Sprinter offers Crosswind Assist<sup>3</sup> as a standard safety feature on 2500 models.

Sudden, unexpected crosswinds can sometimes cause a vehicle to leave its driving lane. At speeds over 50 mph, the vehicle may use a gentle, course-correcting brake application to help stabilize it in strong, gusting crosswinds.

Plus, as the only van in its segment featuring standard Load-Adaptive Electronic Stability Program (ESP)<sup>5</sup>, the Sprinter helps you perform your job with less worry.

This dynamic handling system actively intervenes to help ensure that your Sprinter Van stays firmly under your control. With available advanced safety systems such as Blind Spot Assist,<sup>9</sup> Lane Keeping Assist,<sup>10</sup> Highbeam Assist, and COLLISION PREVENTION ASSIST,<sup>11</sup> we'll help keep you secure today — and down the road.



Crosswind Assist<sup>3</sup> can gently engage individual brakes to quickly help stabilize your Sprinter Van and boost safety in strong, gusting crosswinds. This standard feature helps you ensure that your vehicle remains in its lane at highway speeds.

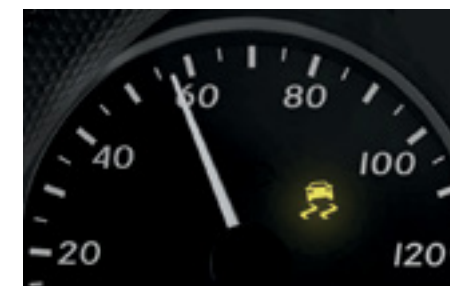

The Load-Adaptive Electronic Stability Program (ESP)<sup>5</sup> dynamic handling system actively intervenes to help keep the van firmly under control and safe by automatically braking individual wheels and reducing engine power to help stabilize the vehicle if wheelspin, understeer, or oversteer is detected.



COLLISION PREVENTION ASSIST<sup>11</sup> is a radar-based proximity warning system that can issue visual and audible warnings when vehicles traveling ahead come within a potentially dangerous distance. In emergency situations, boosted braking pressure assists automatically to help prevent rear-end collisions.

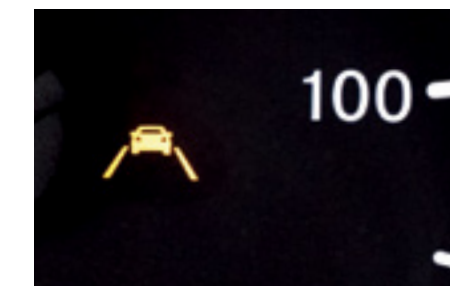

Lane Keeping Assist<sup>10</sup> can provide you with visual and audible warnings if the vehicle leaves its lane unintentionally. A camera in the windshield monitors the road ahead and helps detect when you may have veered away from lane markings.

STANDARD HIGHLIGHTS: CROSSWIND ASSIST<sup>3</sup> | CLASS-LEADING INTERIOR STANDING HEIGHT<sup>2</sup> | REAR DOORS OPEN 270 DEGREES | WIDE SIDE-DOOR OPENINGS | CLASS-LEADING PAYLOAD<sup>2</sup>

OPTIONAL HIGHLIGHTS: SUPER HIGH ROOF | LOW-RANGE 4X4 | LASHING RAILS<sup>13</sup> | CARGO TIE-DOWNS<sup>13</sup> | SIDE WALL PANELING

# SMART. AND STRONG.

Don't just keep up with your competition — pass them like a Sprinter. Built smarter from the ground up, the Sprinter Cargo Van created the blueprint for the hardworking commercial van. Over the course of five million miles and 17,000 quality checkpoints, the Sprinter was rigorously tested to ensure that your business is powered by an advanced, spacious, and reliable commercial van.

The Sprinter Cargo Van's cavernous interior space, tall standing height, available

Super High Roof, and class-leading payload capacities<sup>2</sup> give you all the room you need to succeed. A turbo diesel engine<sup>1</sup> and class-leading service intervals<sup>2</sup> of up to 20,000 miles can help raise your productivity and lower your cost of ownership.<sup>4</sup>

If the strength of your business relies on the performance of your cargo van, the Sprinter has everything you're looking for — and more.

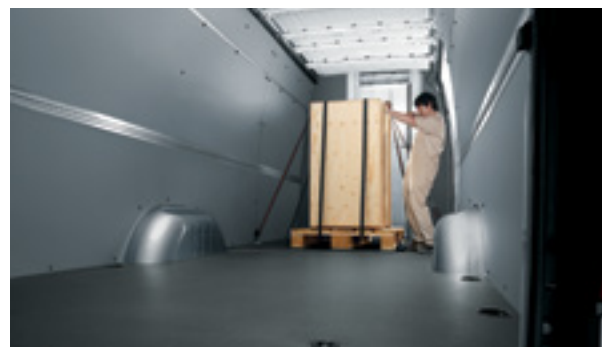

With up to 563.6 cu. ft. of cargo space, the Sprinter offers plenty of room to work.



A Super High Roof option gives the Sprinter a class-leading interior standing height of seven feet<sup>2</sup> giving you the freedom to take your business to new heights.



*"Every van owner secretly wishes he or she had a Sprinter."* — Truck Trend

*\*Optional equipment shown*





STANDARD HIGHLIGHTS: CROSSWIND ASSIST<sup>3</sup> | CLASS-LEADING INTERIOR STANDING HEIGHT<sup>2</sup> | REAR DOORS OPEN 270 DEGREES | WIDE SIDE-DOOR OPENINGS | CLASS-LEADING PAYLOAD<sup>2</sup>

OPTIONAL HIGHLIGHTS: SUPER HIGH ROOF | LOW-RANGE 4X4 | LASHING RAILS<sup>13</sup> | CARGO TIE-DOWNS<sup>13</sup> | SIDE WALL PANELING

# INNOVATIONS AT EVERY TURN.

Whatever you do, Freightliner has the Cargo Van to fit your business. From plumbers and painters to contractors and caterers, more and more businesses rely on the Sprinter's class-leading capabilities, advanced innovations, and low total cost of ownership to help them grow stronger.

Standard Crosswind Assist<sup>3</sup> can help keep your van under tight control at highway speeds. Extended length and available Super High Roof models increase cargo volume and customization possibilities. And you'll appreciate interior ergonomics and connectivity capabilities that make you as comfortable on the road as you are at home.

If you work in conditions affected by harsh climates and less-than-ideal road conditions, the Sprinter Cargo Van offers an optional 4x4 drive train, with on-demand 4-wheel drive. Powered by a spirited V6 turbo diesel engine,<sup>1</sup> the Sprinter 4x4 Cargo Van keeps your business moving even in harsh weather and driving conditions.

Select the Sprinter Cargo Van that's built for your business. Our highly varied configuration options give you a choice of three wheelbases, three body lengths, three cargo-area heights, and three gross vehicle weight classes. You'll see that, at any size, the Sprinter Cargo Van is designed to meet and exceed your expectations.



In addition to the class-leading 270-degree fold-back rear doors,<sup>2</sup> the Sprinter is also available with a driver-side sliding door, allowing you clear rear access in even the tightest situations.



A standard 4-cylinder turbo diesel engine<sup>1</sup> offers up to 18%<sup>7</sup> fuel savings versus the 6-cylinder model, helping your business lower its operating costs significantly.



The standard Super Single tire configuration on the 3500 model provides Best-in-Class payload<sup>2</sup> using a single-wheel rear axle, without sacrificing the cargo-loading capacity that is lost with the larger wheel wells of dual-wheel rear axles.

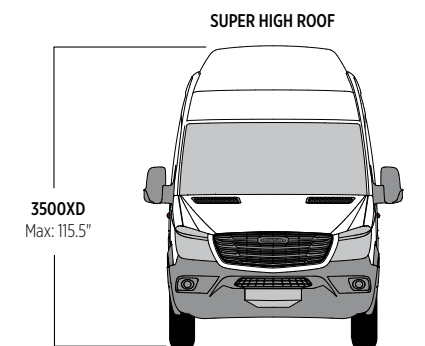
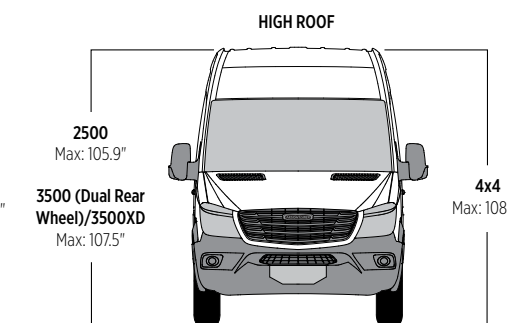
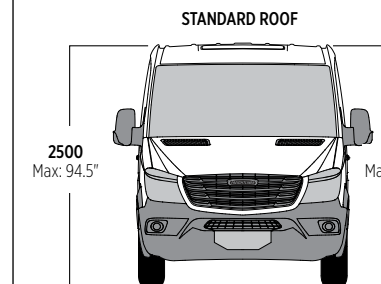
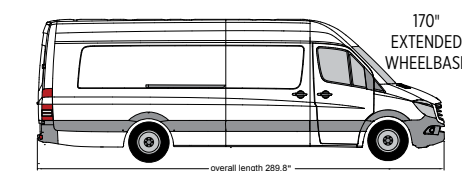
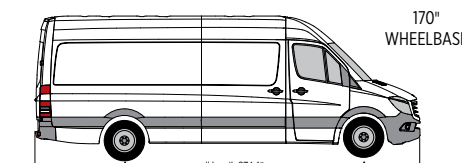
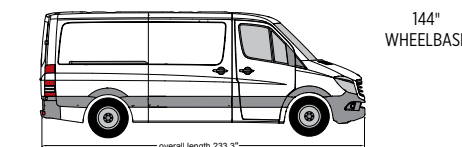



STANDARD HIGHLIGHTS: TINTED FIXED FRONT SIDE WINDOWS | PADDED ARMRESTS | REMOVABLE REAR BENCH | CROSSWIND ASSIST<sup>3</sup> | ONLY CREW VAN IN ITS CLASS

OPTIONAL HIGHLIGHTS: LOW-RANGE 4X4 | CARGO STRAPS, D-RINGS<sup>13</sup> | CARGO TIE-DOWNS<sup>13</sup> | MULTIFUNCTION STEERING WHEEL

# TAKE FIVE.

The Sprinter Crew Van has room for nearly everything — and everyone. Transport cargo and up to five people with a removable 3-seat crew bench that provides the flexibility to bring your workforce to any job.

Tinted fixed front side windows offer better sightlines for safety, while bench seating with room for three offers comfort and durability. The Sprinter Crew Van 4x4 with optional 4-wheel drive helps you work without worry in different seasons, terrains, and climates. Plus, standard Crosswind Assist<sup>3</sup> helps keep your vehicle on course in strong winds.

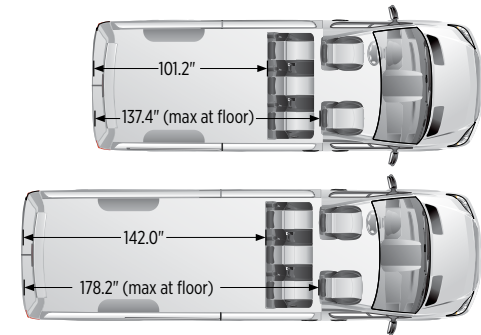

Create the Sprinter Crew Van that fits your business best. Choose from two wheelbases, two body lengths, and two cargo-area heights.



A removable rear 3-seat bench covered in durable upholstery gives your crew a roomy, safe, and comfortable space.



Crew Vans feature padded armrests and tinted fixed front side windows.





STANDARD HIGHLIGHTS: ROOF-MOUNTED REAR AIR CONDITIONER | CLASS-LEADING INTERIOR STANDING HEIGHT<sup>2</sup> | WIDE SIDE-DOOR OPENINGS | CROSSWIND ASSIST<sup>3</sup> | 3-POINT SEAT BELTS & HEADRESTS FOR EVERY SEAT | REAR DOORS OPEN 270 DEGREES

OPTIONAL HIGHLIGHTS: LOW-RANGE 4X4 | ELECTRIC SLIDING STEP

# FIRST CHOICE FOR TRANSPORTING PEOPLE.

The Freightliner Sprinter Passenger Van offers transportation with unrivaled style, safety, and innovation. First-class features include room for up to 12 people, an interior standing height of up to 6 ft. 3 in., a spacious rear storage area, ergonomic durable rear passenger seating with individual headrests, and integrated 3-point seat belts at each seating position.

Your advantages don't stop there. An optional 4x4 model assures greater traction, safety, and sure-footed handling in a variety of weather and road conditions. An optional V6 turbo diesel engine,<sup>1</sup> as well as advanced safety features including an available rearview camera,<sup>12</sup> make it a strong choice for driving your business ahead.



An impressive interior standing height of up to 6'3" provides greater passenger comfort with plenty of room to move.



*"A manageable driving position and impressive handling make the [Sprinter] van pleasant and surprisingly maneuverable around town, while electronic aids help fight the wind gusts at speed."*  
— Edmunds

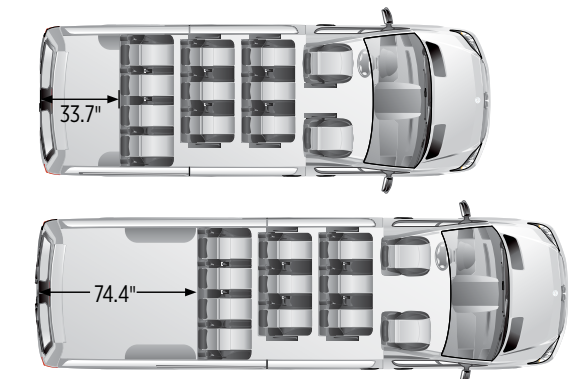

Select from our configuration options and create the Sprinter Passenger Van that fits your business best.

STANDARD HIGHLIGHTS: BEST-IN-CLASS PAYLOAD<sup>2</sup> | BODY & CONVERSION SOLUTIONS | 26.4 GALLON FUEL TANK | FLAT FRAME RAILS | RACK-AND-PINION STEERING | 96" EXTENDED EXTERIOR MIRRORS

OPTIONAL HIGHLIGHTS: MULTIFUNCTION STEERING WHEEL

# BUILD ON THE ULTIMATE FOUNDATION.

Whether you're building a state-of-the-art ambulance, RV, luxury limousine, or box delivery vehicle, the Freightliner Sprinter Cab Chassis/Cutaway<sup>14</sup> is the perfect way to begin. With Best-in-Class payload,<sup>2</sup> its refined yet rugged platform is built for big thinkers — like you.

Powered by a standard 4-cylinder turbo diesel engine<sup>1</sup> that lowers fuel costs by up to 18%<sup>7</sup> versus the 6-cylinder, the Sprinter Cab Chassis/Cutaway<sup>14</sup> is compatible with a vast range of bodies and features rack-and-pinion steering, independent front suspension, and road-tested

reliability. A flat, unobstructed frame rail, available roof- and rear-wall deletion, and plenty of wiring options help you create a customized vehicle that fits your business perfectly.

The lightweight, sturdy frame offers straight-line stability and roll resistance to help you drive with confidence, regardless of the load. Two available wheelbases, both featuring GVWRs of 11,030 pounds, and the most advanced safety features available in any cab chassis/cutaway offer incredibly sound reasons to build your business on the ultimate base.

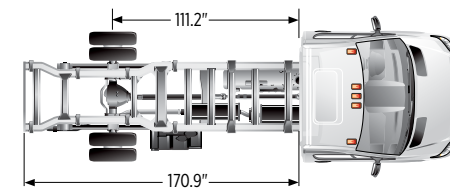
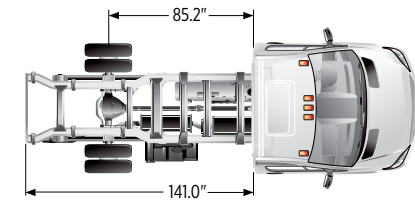

Choose between two wheelbases (144" and 170" — both with GVWRs of 11,030 pounds), and build the Sprinter Cab Chassis/Cutaway<sup>14</sup> that works best for you.

*(All measurements in inches)*



CLASS-LEADING PAYLOAD<sup>2</sup> | CROSSWIND ASSIST<sup>3</sup> | LOAD-ADAPTIVE ESP<sup>5</sup> | THREE EASY OPTIONAL PACKAGES

# IT'S TIME TO GO TO WORK.

The Sprinter WORKER Cargo Van can hold over 3,500 lbs. of payload and has a maximum cargo volume of 486.5 cu. ft. While the capacities are impressive, the Sprinter WORKER Cargo Van takes it a step further by letting you choose between two different wheelbase lengths and the standard 4-cylinder or available V6 turbo diesel engines.<sup>1</sup> Working hard means staying on the road, and you'll do that as well with an up to 20,000-mile service interval.<sup>4</sup>

*Limitations in standard and optional equipment — see your dealer for details.*

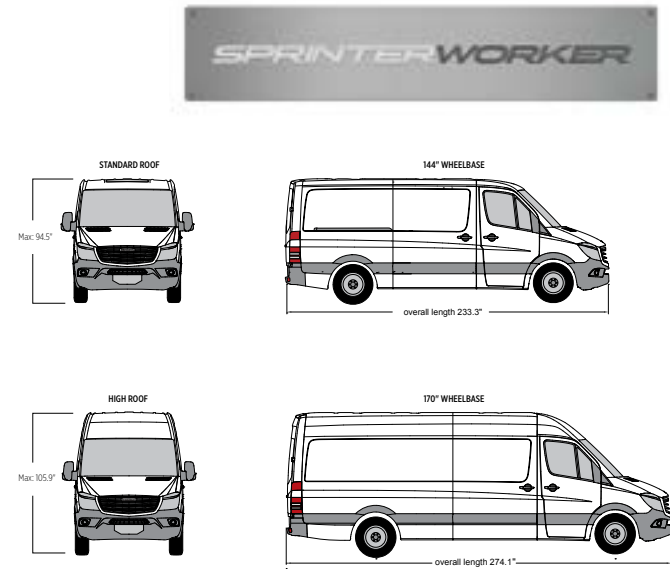

ROOF-MOUNTED REAR AIR CONDITIONER | SEATS UP TO TWELVE | CROSSWIND ASSIST<sup>3</sup> | TWO EASY OPTIONAL PACKAGES

# FITS UP TO 12 PEOPLE AND YOUR BUDGET.

It's time for a van that does more without costing more. It's time for the Sprinter WORKER Passenger Van. The Sprinter WORKER Passenger Van is the perfect way to keep costs down without sacrificing comfort or reliability. The low cost of ownership and 4-cylinder turbo diesel engine<sup>1</sup> that saves up to 18%<sup>7</sup> on fuel costs versus the 6-cylinder will have you operating more efficiently every day. At the same time, your passengers will be treated to 64.1" of interior standing height and 68.6 cu. ft. of cargo volume. Your daily trips will be more secure, knowing that you have advanced safety features like Crosswind Assist<sup>3</sup> and Load-Adaptive Electronic Stability Program (ESP<sup>®</sup>)<sup>5</sup> riding with you. The Sprinter WORKER Passenger Van. It's good for you and your business.

*Limitations in standard and optional equipment — see your dealer for details.*

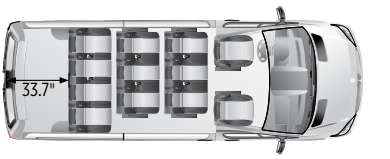

MOBILE WORKSHOPS | SERVICE INTERIOR VANS | DRY BOX BODIES | DELIVERY VANS | REFRIGERATION VANS | RECREATIONAL VEHICLES | LIMOUSINES | SHUTTLE BUSES | MOBILE OFFICES | AMBULANCES | PARATRANSIT VANS | AND MUCH MORE

# IF YOU CAN IMAGINE IT, WE CAN MAKE IT HAPPEN.

**MASTER SOLUTIONS™**

You're the expert in your trade, and your van is the tool with which to get the job done. MasterSolutions<sup>15</sup> allows you to quickly configure your van and order directly via your Freightliner Sprinter dealer to get you exactly the van you want right when you need it, so you can concentrate on finishing the job.

MasterSolutions providers Knapheide and Auto Truck bring you a portfolio of turnkey solutions for your vocation — anything from Sortimo or Ranger shelving to refrigeration or even transportation of people at a preferred price. These preconfigured solutions from industry-leading manufacturers are customized to fit your Freightliner Sprinter. The ordering process is streamlined, and installation is simple: all MasterSolutions<sup>15</sup> can be fitted directly as Ship-Thru, ensuring seamless integration, quick delivery, and consistent quality.

**MASTER UPFITTER**

You have a concept in mind — let a Freightliner Sprinter MasterUpfitter build it for you. Our job is to manufacture a van that is ready to fit your ultimate upfitting needs. With the Best-in-Class cargo volume of the Sprinter<sup>2</sup> or the impressive 6,400 lbs. of payload on the Sprinter Cab Chassis, each Freightliner Sprinter Van is a blank canvas on which you can create a design to meet your specific needs.

Whether you are in need of a simple work van interior, a mobile veterinarian clinic, or the ultimate RV, Freightliner Sprinter is making you mobile and taking your business to new places.

Qualified Upfitters adhere to the Upfitting Guidelines to become part of the Freightliner Sprinter MasterUpfitter network. These masters of their trade are committed to the highest engineering standards and levels of customer satisfaction. Working with a MasterUpfitter gives you the flexibility to be creative and the assurance that Freightliner is here to support your ideas.





RETAIL LOAN | COMPLETE ADVANTAGE LEASE<sup>16</sup> | FMV LEASE | TRAC LEASE<sup>17</sup> | ZERO-TRAC LEASE<sup>18</sup>

# SIMPLIFIED—AND SMART—FINANCING SOLUTIONS.

Through Daimler Truck Financial, we offer a variety of financing products and solutions with flexible benefits and competitive rates tailored specifically to meet the needs of your business.<sup>19</sup>

For more information, visit: <http://www.freightlinersprinterusa.com/freightliner/shopping-tools/finance-solutions>

## Retail Loan

These simple-interest, fixed-payment packages lock in interest rates and can include van and upfit equipment, as well as aftermarket products, in one contract.

## Complete Advantage Lease<sup>16</sup>

Everyone has a budget, and when it comes to running your business, you can appreciate the value of even, predictable expenses. Complete Advantage Lease offers one consistent payment for your leased vehicle and includes coverage for preventive maintenance and wear and tear items plus an Extended Limited Warranty. Complete Advantage Lease includes:

- Fixed monthly payment
- Preventative maintenance
- Extended Limited Warranty coverage
- Replacement of common wear items
- Roadside Assistance
- Service from factory-trained technicians
- No acquisition fee or up-front payment
- No turn-in fee

## FMV Lease

- A closed-end lease agreement is also known as a “walkaway lease,” since the lessee can simply turn in the vehicle and walk away at lease maturity after meeting all of the obligations of the contract, subject to certain return conditions and mileage restrictions.

## TRAC Lease<sup>17</sup>

- A Terminal Rental Adjustment Clause (TRAC) Lease<sup>17</sup> doesn't require any acquisition fee, up-front payment, or excess mileage charges, and lease payments may be expensed against income.
- Owners are responsible for the residual value of the vehicle.

## Zero-TRAC Lease<sup>18</sup>

- Offers many of the same benefits as a TRAC, but is a fully amortized lease that offers ownership of the vehicle at lease end with little or no cash outlay.

EXTENDED LIMITED WARRANTY<sup>20</sup> (ELW) |

ROADSIDE ASSISTANCE<sup>21</sup> |

PREPAID MAINTENANCE |

CHOOSE YOUR PLAN

# CARE FOR THE VAN THAT CARES FOR YOUR BUSINESS.

## Extended Limited Warranty<sup>20</sup> (ELW)

We understand how vehicle downtime can impact your business. Protect one of your most valuable investments with the no-hassle convenience of a Freightliner Sprinter Extended Limited Warranty.<sup>20</sup>

The Freightliner Sprinter Extended Limited Warranty<sup>20</sup> offers several attractive features:

- Repairs by factory-trained technicians utilizing high-tech diagnostic equipment
- Repairs completed with Genuine Sprinter Parts
- No risk to you; may be cancelled at any time prior to the New Vehicle Limited Warranty expiration for a full refund
- Honored by all authorized Freightliner Sprinter dealerships
- No deductibles or cumbersome claims processing
- No approvals required prior to repairs

Choose the plan that fits your Sprinter and your business:

- 1-year/up to 100,000 miles
- 2-year/up to 125,000 miles
- 3-year/up to 150,000 miles
- 4-year/up to 175,000 miles

## Roadside Assistance<sup>21</sup>

All Freightliner Sprinters come standard with our 24-hour Roadside Assistance Program<sup>21</sup> and expert advice 24/7 through the Daimler Customer Assistance Center. Roadside Assistance<sup>21</sup> covers your Sprinter — even after the warranty period (additional charges apply).

## Prepaid Maintenance

Save time and money by prepaying for routine services. Simply pay for your Sprinter's maintenance in advance and lower your ownership costs as you protect against potential unexpected cost increases for parts and service down the road.

Prepaid Maintenance helps you and your business in many ways:

- Save money — up to 30%<sup>22</sup>—on routine maintenance costs, including parts, labor, and taxes
- Lock in costs for required services and protect against cost increases for parts and service
- Service is performed according to factory standards and specifications by factory-trained technicians at any authorized Freightliner Sprinter dealer using Genuine Sprinter Parts
- Select the plan that meets your driving needs
- Choose from flexible payment options — prepay the full amount or build the cost into your monthly payment
- Plan is transferable to subsequent Sprinter owner
- Purchase your plan anytime up to the first service or 20,000 miles,<sup>4</sup> whichever comes first

## Choose the plan that's best for you:

- Two services or up to 40,000 miles
- Four services or up to 80,000 miles
- Six services or up to 120,000 miles
- Eight services or up to 160,000 miles

Can be purchased with or without AdBlue® (an environmentally friendly exhaust gas cleaning system).



FLOOR PROTECTION | CARGO MANAGEMENT | STORAGE SOLUTIONS

EXTERIOR/INTERIOR APPEARANCE | ELECTRONICS

# ACCESSORIES

Sprinter accessories add even more brains and brawn to the hardest-working vehicle in the business. Below is a selection of the accessories you can add to maximize productivity and keep your Sprinter ahead of the pack.



## All-Season Front Floor Mats

Designed to seamlessly fit your Sprinter Van's contours, these rugged, dirt-repellent natural rubber floor mats protect your Sprinter from water, snow, slush, and mud. Set of two. Slip-free. Embossed logo.



## Becker® MAP PILOT® Navigation System<sup>23</sup>

This advanced navigation upgrade fully integrates with your Sprinter's in-dash displays and steering-wheel controls. Speech recognition allows for hands-free navigation input. Vivid maps offer a detailed view of street names and points of interest.



## Trailer Hitch

Take advantage of your Sprinter's considerable hauling capacity with a trailer hitch designed specifically for your model. Features a corrosion-resistant surface treatment for long life.



## Stowage Box (for Twin Co-Driver Seat)

Extra space is right at hand. Raise the seat cushion of the twin co-driver seat, and secure and store important items within easy reach. Crafted from rugged ABS plastic.

## OPTIONAL EQUIPMENT

Freightliner offers innovative options that enhance your Sprinter Van's capabilities, appearance, performance, comfort, and safety. Select from the many individual options and optional packages that help your Sprinter work smarter and harder for your business. Below is a list of our most popular optional packages. See your authorized Freightliner Sprinter dealer for a complete list.

	Cargo Van	Crew Van	Passenger Van	Cab Chassis/Cutaway		Cargo Van	Crew Van	Passenger Van	Cab Chassis/Cutaway		Cargo Van	Crew Van	Passenger Van	Cab Chassis/Cutaway
<b>Active Safety Plus Package</b>					<b>Driver Comfort Package</b>					<b>Passenger Van Heating Pack 2</b>				
4.2" pixel matrix display with chrome dials	•	•	•	•	12V outlet at driver's seat base	•	•	•	•	Heavy duty fuel-fired pre-heater/booster (34,000 BTU)	–	–	•	–
Blind Spot Assist <sup>9</sup>	•	•	•	–	Comfort seat, driver	•	•	•	•	Rear cabin heater and vents	–	–	•	–
COLLISION PREVENTION ASSIST <sup>11</sup>	•	•	•	•	Comfort seat, passenger	•	•	•	•	Remote control for auxiliary heater	–	–	•	–
Emergency flashlight	•	•	•	•	Hinged lid for storage compartment	•	•	•	•	<b>Premium Appearance Package</b>				
First aid kit	•	•	•	•	Two additional master keys	•	•	•	•	Bi-Xenon headlamps	•	•	•	–
Heated and electrically adjustable mirrors	•	•	•	•	<b>Driver Efficiency Package</b>					Headlamp cleaning system	•	•	•	–
Highbeam Assist	•	•	•	•	Becker <sup>®</sup> MAP PILOT <sup>®</sup> navigation system <sup>23</sup>	•	•	•	•	Light alloy wheels	•	•	•	–
Lane Keeping Assist <sup>10</sup>	•	•	•	•	Cruise control	•	•	•	•	<b>Suspension Package 3</b>				
Light and rain sensor	•	•	•	•	Fog lamps	•	•	•	•	Chassis for application A	•	–	–	–
Multifunction steering wheel with trip computer	•	•	•	•	Rearview camera <sup>12</sup>	•	•	•	–	Stabilizer, rear axle, under frame	•	–	–	–
Overhead control panel with two reading lamps	•	•	•	•	<b>Lighting Package</b>					Stabilizer, reinforced at front axle	•	–	–	–
Windshield with sun filter band	•	•	•	•	Bi-Xenon headlamps	•	•	•	•	<b>Workspace Access Package</b>				
<b>Active Safety Plus Package with PARKTRONIC</b>					Headlamp cleaning system	•	•	•	•	12V outlet in load compartment	•	–	–	–
Includes all elements of Active Safety Plus Package plus PARKTRONIC	•	•	•	–	<b>Multifunction Wheel/Display Package</b>					Additional battery for retrofit	•	–	–	–
<b>Cargo Protection Package</b>					4.2" pixel matrix display with chrome dials	•	•	•	•	Assist handle, B-pillar	•	–	–	–
Cargo lashing rails, head height <sup>15</sup>	•	–	–	–	Multifunction steering wheel	•	•	•	•	Assist handle, left rear door	•	–	–	–
Cargo lashing rails, waist level <sup>15</sup>	•	–	–	–	<b>Passenger Van Heating Pack 1</b>					Assist handle, right rear door	•	–	–	–
Cargo straps, D-rings <sup>15</sup>	•	–	–	–	Fuel-fired heater booster (17,000 BTU)	–	–	•	–	Ceiling light in rear compartment, LED	•	–	–	–
Lashing rails, floor-level <sup>15</sup> (plus 4 anchors)	•	–	–	–	Rear cabin heater and vents	–	–	•	–	Cutoff relay for additional battery	•	–	–	–
Side wall paneling, full hardboard	•	–	–	–						Rear door step	•	–	–	–
Sliding door, two-stage opening	•	–	–	–										

## WORKER CARGO OPTIONS

	WORKER Cargo		WORKER Cargo		WORKER Cargo
<b>Convenience Package</b>		<b>Utility Package</b> includes Convenience Package		<b>Overtime Packages</b> includes Convenience and Utility Packages	
12V power outlet, driver seat base	•	Assist handle, left rear door	•	Audio 15 head unit	•
Cruise control	•	Assist handle, right rear door	•	Blind Spot Assist <sup>9</sup>	•
Heated and electrically adjustable exterior mirrors	•	Hinged lid for storage compartment	•	Emergency flashlight	•
Light and rain sensor	•	Interior rearview mirror	•	First aid kit	•
Multifunction steering wheel with trip computer	•	Keys, two additional masters	•	Highbeam Assist	•
Overhead control panel with two reading lights	•	LED ceiling lights in cargo compartment	•	Rearview camera <sup>12</sup>	•
Pixel matrix display	•	Rear door step	•		
Trailer pre-wiring	•	Wood floor	•		
Windshield with sun filter band	•				

## WORKER PASSENGER OPTIONS

	WORKER Passenger		WORKER Passenger
<b>Convenience Package</b>		<b>Overtime Package</b> includes Convenience Package	
12V power outlet, driver seat base	•	12V power outlet in rear compartment	•
Blind Spot Assist <sup>9</sup>	•	Audio 15 head unit	•
Convenience lighting in load/passenger compartments	•	Black Leatherette fabric	•
Cruise control	•	Fog lamps	•
Heated and electrically adjustable exterior mirrors	•	Heated rear window, washer/wipers	•
Light and rain sensor	•	Illuminated front exits	•
Multifunction steering wheel with trip computer	•	Rearview camera <sup>12</sup>	•
Pixel matrix display	•		
Windshield with sun filter band	•		



**SPRINTER EXTERIOR & INTERIOR**

EXTERIOR: NON-METALLIC



EXTERIOR: METALLIC



INTERIOR



Paint colors are restricted for Passenger Vans. Only paints for PVs are: 040, 147, 197, 243, 701, 744, 759, 764, and 890. Color options are limited for WORKER models.

**FREIGHTLINER MODEL RANGE**

*SPRINTER MODELS AT A GLANCE*

		Body Length	Roof Heights	2500 Model 8,550 lbs. perm. GVWR		3500 Model 9,990 lbs. perm. GVWR		3500XD Model 11,030 lbs. perm. GVWR	
CARGO VAN	Standard (with 144-inch wheelbase)	Standard Roof		4x4 <small>SPRINTERWORKER</small>					
			High Roof		4x4 <small>SPRINTERWORKER</small>		Dual Rear Wheel Super Single Rear Tires		4x4
	Long (with 170-inch wheelbase)	High Roof		4x4 <small>SPRINTERWORKER</small>		Dual Rear Wheel Super Single Rear Tires		4x4	
			Extra-long (with 170-inch wheelbase and long rear overhang)	High Roof		4x4		Dual Rear Wheel Super Single Rear Tires	
	Long (with 170-inch wheelbase)	Super High Roof							
	Extra-long (with 170-inch wheelbase and long rear overhang)	Super High Roof							
CREW VAN	Standard (with 144-inch wheelbase)	Standard Roof		4x4					
		High Roof		4x4					
	Long (with 170-inch wheelbase)	High Roof		4x4					
PASSENGER VAN	Standard (with 144-inch wheelbase)	Standard Roof		4x4 <small>SPRINTERWORKER</small>					
		High Roof		4x4					
	Long (with 170-inch wheelbase)	High Roof							
CAB CHASSIS/ CUTAWAY <sup>14</sup>	Standard (with 144-inch wheelbase)	Standard Roof							
	Long (with 170-inch wheelbase)	Standard Roof							

## ENDNOTES

---

MY17 Sprinter available winter 2017.

1. Requires the use of ultra-low-sulfur diesel fuel. Freightliner Sprinters are approved to use B5 biodiesel (approved diesel fuel with a maximum 5% biodiesel content). The only approved biodiesel content is one that both meets ASTM D6751 specifications and has the oxidation stability necessary to prevent deposit-/corrosion-related damages to the system (min. 6h, proven by EN14112 method). Please see your service station for further information. If the B5 biodiesel blend does not clearly indicate that it meets the above standards, please do not use it. The Freightliner Sprinter New Vehicle Limited Warranty does not cover damage caused by fuel standards not approved by Freightliner.
2. Based on a comparison of full-size commercial vans at the time of print.
3. Crosswind Assist can engage automatically when sensing dangerous wind gusts at highway speeds exceeding 50 mph. Performance is limited by wind severity and available traction, which snow, ice, and other conditions can affect. Always drive carefully, consistent with conditions. Feature not available on 3500 and 3500XD models.
4. Driver is responsible for monitoring fluid levels and tire pressure between service visits. See Maintenance Booklet for details.
5. No system, regardless of how advanced, can overcome the laws of physics or correct careless driving. Please always wear your seat belt. Performance is limited by available traction, which snow, ice, and other conditions can affect. Always drive carefully, consistent with conditions. Best performance in snow is obtained with winter tires.
6. From *Autoblog*, May 30, 2015 ©2015 AOL Inc. All rights reserved. Used by permission and protected by the Copyright Laws of the United States. Printing, copying, redistribution, or retransmission of this Content without express written permission is prohibited.
7. Fuel savings estimate of up to 18% according to FTP75 testing of engine OM651 (4-cylinder) versus MY17 OM642 (V6). Individual mileage will vary, based on factors including vehicle load, driving style, road conditions, and fuel quality.
8. Warning: the forces of a deploying airbag can cause serious or fatal injuries to a child under age 13. The safest seating position for your child is in a rear seat, belted into an appropriate, properly installed child seat, or correctly wearing a seat belt if too large for a child seat. See Operator's Manual for additional warnings and information on airbags, seat belts, and child seats.
9. Blind Spot Assist may not be sufficient to avoid all accidents involving vehicles in your blind spot and does not estimate the speed of approaching vehicles. It should not be used as a sole substitute for driver awareness and checking of surrounding traffic conditions. Not available on Cab Chassis/Cutaway.
10. Lane Keeping Assist may be insufficient to alert a fatigued or distracted driver of lane drift and cannot be relied on to avoid an accident or serious injury.
11. COLLISION PREVENTION ASSIST may not be sufficient to avoid an accident. It does not react to certain stationary objects, nor recognize or predict the curvature and/or lane layout of the road or every movement of vehicles ahead. It is the driver's responsibility at all times to be attentive to traffic and road conditions, and to provide the steering, braking, and other driving inputs necessary to retain control of the vehicle. Drivers are cautioned not to wait for the system's alerts before braking, as that may not afford sufficient time and distance to brake safely.
12. Rearview camera does not audibly notify driver of nearby objects and is not a substitute for actively checking around the vehicle for any obstacles or people. Images displayed may be limited by camera field of view, weather, lighting conditions, and the presence of dirt, ice, or snow on the camera.
13. Unsecured cargo can become hazardous in a collision. Always secure cargo.
14. Must select Cutaway packages F05 or F08.
15. MasterSolutions program vehicles are custom, special-order only vehicles modified by the MasterSolutions provider chosen by you. Although the Daimler Vans warranty does not apply to the modifications, separate warranties, offered by the MasterSolutions Provider, may apply. Details are available from your local dealer.
16. Complete Advantage Lease is not available in Virginia, Washington, Wisconsin, and California. Program coverage is based upon the terms and mileage of selected lease. All service must be provided by an authorized Freightliner Sprinter dealership in the U.S.
17. TRAC leases are limited to motor vehicles leased to businesses and used at least 50% of the time for business purposes. Consult your tax or financial advisor for tax and accounting treatments.
18. In some states, this is a taxable transaction at lease end. Sales taxes on the purchase will be due in some states. Check with your tax advisor for details.
19. Actual rates, terms, down payment, and program eligibility will be determined by the Daimler Truck Financial Credit Team based upon creditworthiness of customer.
20. Extended Limited Warranty (ELW) is not available in all states. Contact your local Freightliner Sprinter dealer to verify availability.
21. The Sprinter Roadside Assistance Program is available for vehicles covered under warranty and includes such services as towing, jump-start in the event of a dead battery, and assistance with the installation of a spare tire. Service charges apply for out-of-warranty vehicles.
22. Versus paying for services as you go. Potential savings vary by dealer.
23. Pre-wiring code EV6 required.

©2016 Daimler Vans USA LLC: 303 Perimeter Center North – Ste. 202, Atlanta, GA, 30346 1-877-762-8267

All illustrations and specifications contained in this brochure are based on the latest product information available at the time of publication. All measurements are according to SAE J1100. Daimler Vans USA reserves the right to make changes at any time, without notice, to colors, materials, equipment, specifications, and models. Any variations in colors shown are due to reproduction variations of the printing process. Illustrations may include test situations. Some vehicles may be shown with non-U.S. equipment. Some vehicles are shown with optional equipment available at extra cost. Some optional equipment may not be available individually and/or on all models. For current information regarding the range of models, standard features, optional equipment, and/or colors available in the U.S. and their pricing, please contact your nearest authorized Freightliner Sprinter dealer. All rights reserved. Becker® is a registered trademark of Harman Becker Automotive Systems GmbH. Bluetooth® is a registered trademark of Bluetooth SIG, Inc.

[www.freightlinersprinterusa.com](http://www.freightlinersprinterusa.com)

Daimler Vans USA LLC SFL-16-1030 Printed in U.S.A.

